

### Datasheet

## Overview

The ATM33 Wireless SoC Series is part of a family of extreme low-power Bluetooth® 5.3 system-on-chip (SoC) solutions. This Bluetooth Low Energy SoC integrates a Bluetooth 5.3 compliant radio with ARM® Cortex® M33F application processor, 128 KB Random Access Memory (RAM), 64 KB Read Only Memory (ROM), 512 KB nonvolatile memory (NVM), 1 MB extended flash storage (selected package), and state-of-the-art power management to enable maximum lifetime in battery-operated devices.

The extremely low power ATM33 Series SoC, with a 0.85 mA radio receiver and a 2.5 mA radio transmitter power consumption, is designed to extend battery life for the Internet-of-Things (IoT) markets. Support for low duty cycle operation allows systems to run for significantly longer periods without battery replacement. Innovative wake-up mechanisms are supported to provide options for further power consumption reduction.

## Applications

### Industrial and Enterprise

- Industrial IoT Sensors
- Remote Monitors

### Healthcare

- Health Monitors
- Sports and Fitness

### Home

- Advanced Home Automation
- Advanced Remote Control
- Human Interface Devices (HID)
- Entertainment

### Personal

- Gaming
- Advanced Wearable
- Personal Tracking Devices

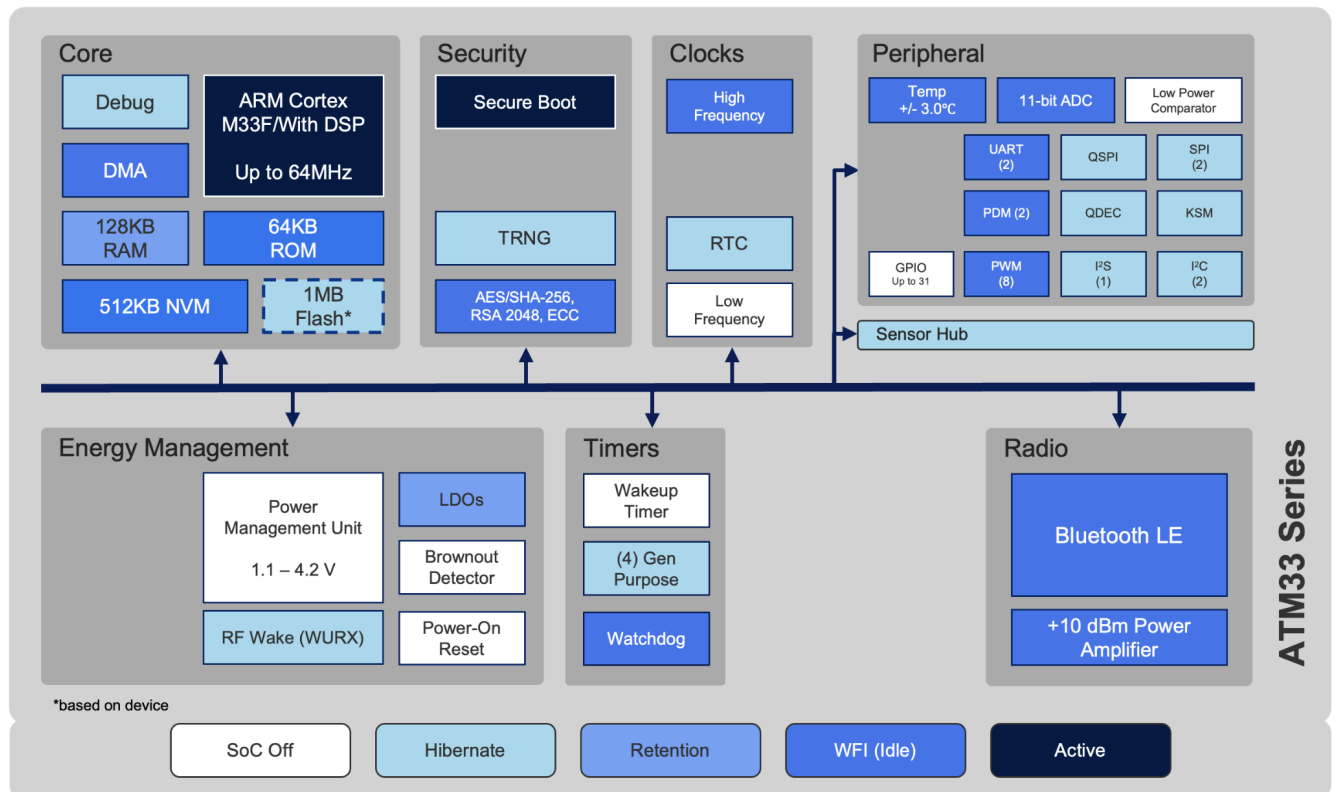

## Features

### Bluetooth LE

- Bluetooth Low-Energy 5.3 compliant
- 2 Mbps, 1 Mbps, 500 kbps, and 125 kbps PHY rates
- Supports Bluetooth Angle-of-Arrival (AoA) and Angle-of-Departure (AoD) direction finding

### MCU and Memory

- 64 MHz ARM® Cortex® M33F MCU
- 64 KB ROM, 128 KB RAM, 512 KB NVM, 1 MB extended flash storage (selected package)
- Retention RAM configuration: 16 KB to 128 KB in 16 KB step sizes
- 16 MHz / Optional 32.768 kHz Crystal Oscillator

### Security

- ARM® TrustZone®, HW Root of Trust, Secure Boot, Secure Execution & Debug
- AES-128/256, SHA-2/HMAC 256 Encryption/Cryptographic Hardware Accelerators
- True Random Number Generator (TRNG)

### RF and Power Management

- Fully integrated RF front-end
  - Rx Sensitivity: -95 dBm
  - Tx Power: +10 dBm
- Sensor Hub
- RF wakeup receiver
- 1.1 V to 4.2 V battery input voltage with integrated Power Management Unit (PMU)

- Radio power consumption with 3 V battery
  - Rx @ -95 dBm: 0.85 mA
  - Tx @ 0 dBm: 2.5 mA
- SoC typical power consumption with 3 V battery including PMU
  - Active Rx @ -95 dBm: 1.4 mA
  - Active Tx @ 0 dBm: 3.0 mA
  - Retention @ 32 KB RAM: 1.8  $\mu$ A
  - Hibernate: 1.3  $\mu$ A
  - Hibernation with Wakeup Receiver: 1.6  $\mu$ A
  - SoC Off: 400 nA

### Interfaces

- I2C (2), I2S, SPI (2), UART (2), PWM (8), GPIOs (21 or 31 depending on the package option)
- Quad SPI
- 11-bit Application ADC, 4 external, 5 internal channels, up to 2 Msp
- Two mono or one stereo digital microphone input Pulse Density Modulation (PDM)
- 8 x 20 Keyboard Scan Matrix (KSM) Controller
- Quadrature Decoder (QDEC)
- SWD for interactive debugging

### Package Options

- ATM3330: 7x7 mm, 56-pin QFN (up to 31 GPIOs)
- ATM3325: 5x5 mm, 40-pin QFN (up to 21 GPIOs)
- ATM3325: 5x5 mm with extended storage, 40-pin QFN (up to 18 GPIOs)
- ATM3325: 49L WLCSP (up to 21 GPIOs)

## Table of Contents

<b>Overview</b>	<b>1</b>
<b>Applications</b>	<b>1</b>
<b>Features</b>	<b>2</b>
<b>1 Functional Description</b>	<b>6</b>
1.1 MCU & Memory	6
1.1.1 Clocks	7
1.1.2 Reset	8
1.1.3 Power Modes	8
1.2 Bluetooth LE Radio	8
1.2.1 Link Controller	9
1.2.2 Modem	9
1.3 Wakeup Receiver	10
1.4 Power Management Unit (PMU)	11
1.4.1 PMU Configurations	12
1.5 Security	12
1.6 Sensor Hub	12
1.7 OTP Access	13
1.8 Timers and Interrupts	13
1.8.1 Wakeup Timer	13
1.8.2 General Purpose Timers	13
1.8.3 Interrupts	13
1.9 Peripherals and I/O	14
1.10 Pin Multiplexing	16
<b>2 Electrical Specification</b>	<b>17</b>
<b>3 Pinout Description</b>	<b>25</b>
3.1 ATM3330-5DCAQN 7x7 mm, 56-pin QFN Pinout	25
3.2 ATM3325-5DCAQK 5x5 mm, 40-pin QFN Pinout	28
3.3 ATM3325-5LCAQK 5x5 mm with Extended Storage, 40-pin QFN Pinout	31
3.4 ATM3325-5DCACM 49L WLCSP Pinout	33
<b>4 Mechanical Drawing</b>	<b>37</b>
4.1 ATM3330-5DCAQN 7x7 mm, 56-pin QFN Package	37
4.2 ATM3325-5DCAQK 5x5 mm, 40-pin QFN Package	39
4.3 ATM3325-5LCAQK 5x5 mm, 40-pin QFN with Extended Storage Package	41
4.4 ATM3325-5DCACM 49L WLCSP Package	43
<b>5 Part Ordering</b>	<b>44</b>

---

<b>Reference Documents</b>	<b>45</b>
<b>Revision History</b>	<b>46</b>

## List of Figures

Figure 1-1	Functional Block Diagram
Figure 1.2-1	Bluetooth LE Radio Block Diagram
Figure 1.3-1	Wakeup Receiver Block Diagram
Figure 3.1-1	ATM3330-5DCAQN 7x7 mm, 56-Pin QFN Pinout (Top View)
Figure 3.2-1	ATM3325-5DCAQK 5x5 mm, 40-Pin QFN Pinout (Top View)
Figure 3.3-1	ATM3330-5LCAQK 5x5 mm with Extended Storage, 40-Pin QFN Pinout (Top View)
Figure 3.4-1	ATM3325-5DCACM 49L WLCSP Pinout (Bottom View)
Figure 4.1-1	ATM3330-5DCAQN 7x7 mm, 56-Pin QFN Mechanical Drawing
Figure 4.1-2	ATM3330-5DCAQN 7x7 mm, 56-Pin QFN Land Pattern
Figure 4.2-1	ATM3325-5DCAQK 5x5 mm, 40-Pin QFN Mechanical Drawing
Figure 4.2-2	ATM3325-5DCAQK 5x5 mm, 40-Pin QFN Land Pattern
Figure 4.3-1	ATM3325-5LCAQK 5x5 mm, 40-Pin QFN with Extended Storage Mechanical Drawing
Figure 4.3-2	ATM3325-5LCAQK 5x5 mm, 40-Pin QFN with Extended Storage Land Pattern
Figure 4.4-1	ATM3325-5DCACM 49L WLCSP Mechanical Drawing

## List of Tables

Table 1.1-1	System Memory Map
Table 1.4-1	PMU External Pins
Table 2-1	Maximum Electrical Ratings

---

Table 2-2	Recommended Operating Conditions
Table 2-3	Radio Transceiver Characteristics
Table 2-4	Wakeup Receiver Characteristics
Table 2-5	PMU Characteristics
Table 2-6	GPIO Characteristics
Table 2-7	Application ADC Characteristics
Table 2-8	Radio Power Consumption
Table 2-9	SoC Power Consumption (3 V)
Table 2-10	SoC Power Consumption (4.2V)
Table 2-11	NVM/RRAM Characteristics
Table 2-12	Flash (Extended Storage) Characteristics
Table 3.1-1	ATM3330-5DCAQN 7x7 mm, 56-pin QFN Pin Description
Table 3.2-1	ATM3325-5DCAQK 5x5 mm, 40-pin QFN Pin Description
Table 3.3-1	ATM3325-5LCAQK 5x5 mm, 40-Pin QFN with Extended Storage Pin Description
Table 3.4-1	ATM3325-5DCACM 49L WLCSP Pin Description
Table 4.1-1	ATM3330-5DCAQN 7x7 mm, 56-Pin QFN Dimensions
Table 4.1-2	ATM3330-5DCAQN 7x7 mm, 56-Pin QFN Land Pattern Dimensions
Table 4.2-1	ATM3325-5DCAQK 5x5 mm, 40-Pin QFN Dimensions
Table 4.2-2	ATM3325-5DCAQK 5x5 mm, 40-Pin QFN Land Pattern Dimensions
Table 4.3-1	ATM3325-5LCAQK 5x5 mm, 40-Pin QFN with Extended Storage Dimensions
Table 4.3-2	ATM3325-5LCAQK 5x5 mm, 40-Pin QFN with Extended Storage Land Pattern Dimensions
Table 4.4-1	ATM3325-5DCACM 49L WLCSP Dimensions
Table 5-1	Part Ordering Numbers

# 1 Functional Description

Figure 1-1 Functional Block Diagram

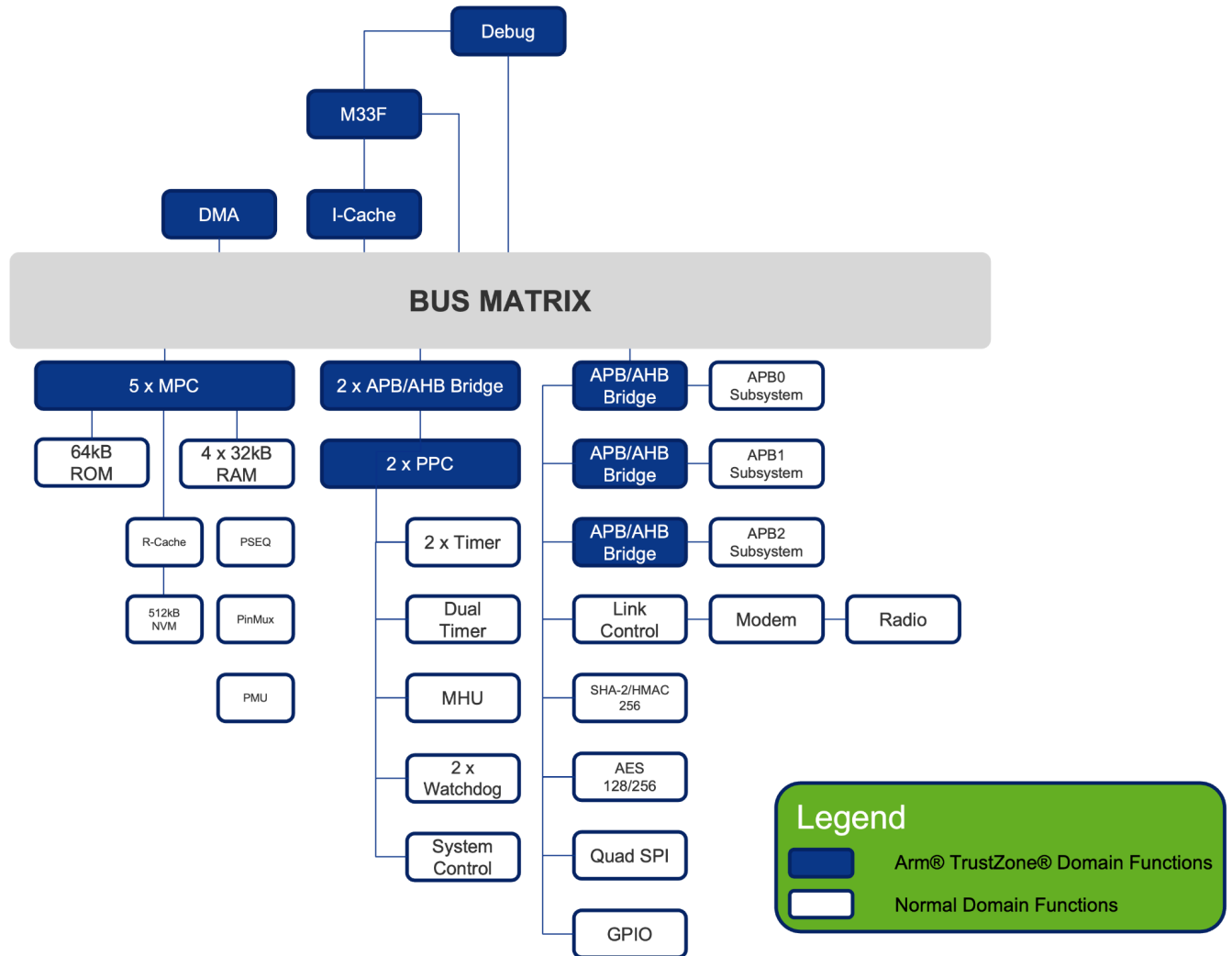

## 1.1 MCU & Memory

The ATM33 Series SoC contains a 64 MHz 32-bit ARM® Cortex®-M33F processor that is optimized for low-power operation. The processor is a little-endian, 32-bit RISC processor which implements the ARMv8-M architecture specification. It supports all Thumb-1/Thumb-2 instructions. It features four breakpoints, a serial access debug port, 103 interrupts, a single cycle multiplier, full wake-on-interrupt support, and two watch points. The M33F includes an IEEE-754 compliant

floating point unit (FPU). The M33F also supports ARMv8-M Digital Signal Processing (DSP) extension for audio and sensor applications. The M33F core is configured with a 4 KB instruction cache to minimize instruction fetch latency.

To reduce latency, software can use the Direct Memory Access (DMA) core for memory to memory copying and for initializing blocks of memory to a constant. When it is in use, the DMA core masters the Advanced Microcontroller Bus Architecture (AMBA) High-performance Bus (AHB) and has higher precedence than the Cortex®-M33F. When interfacing to different slaves, the DMA and MCU can operate concurrently.

The ATM33 Series SoC includes the following memory components:

- ROM: 64 KB of ROM. Core elements of the firmware are placed in ROM to add security, as well as extended application space and reduce latency.
- SRAM: 128KB of SRAM containing both system RAM and data RAM organized as eight 16 KB macros. The power state of each macro in each low power state can be independently controlled.
- NVM: 512 KB of nonvolatile memory to store configuration, calibration data and user application and data.
- FLASH: A quad Serial Peripheral Interface (QSPI) master port to interface with embedded extended flash storage, or an external flash device if needed (up to 16 MB).

The quad SPI master port is equipped with a cache in the read direction to reduce the effective latency of flash accesses. The on-chip system memory is organized as follows:

**Table 1.1-1 System Memory Map**

Start	Stop	Block
0x0000 0000	0x0008 FFFF	ROM + NVM [Non-secure]
0x1000 0000	0x1008 FFFF	ROM + NVM (secure)
0x2000 0000	0x2001 FFFF	SRAM [Non-secure]
0x3000 0000	0x3001 FFFF	SRAM [Secure]
0x4000 0000	0x4030 4FFF	Timers, Slow 32k timer, Watchdog, GPIO, UART, PWM, SPI, KSM, QSPI/FLASH (embedded extended or external), I2C, NVM/OTP, PMU, PSEQ, SWD, GADC, Sensor Hub, PDM, I2S, DMA, SHA-2/HMAC 256 and AES-128/256 [Non-secure]
0x5000 0000	0x5030 4FFF	All of the above peripherals aliased in secure space [Secure]

Non-secure and Secure address aliases are used by the Cortex processor in secure or non-secure mode. The physical mapping of the resource (memory, peripherals) to that alias is managed by the MPC and PPC. Please refer to the **Arm® TrustZone Technology for the Arm v8-M Architecture** manual.

### 1.1.1 Clocks

Primary clock domains on the ATM33 Series SoC are:

- Core clock: 32.768 kHz crystal or an internal RC oscillator (RCOSC) for low power operations
- RF clock: 8 MHz and 16 MHz fixed frequency clocks used by the link controller, modem and radio subsystem
- Backplane clock: 16, 32, 48 or 64 MHz backplane clock used by the MCU and peripherals
- PDM: 12 or 16 kHz fixed frequency PDM clock
- I2S: 16, 24 or 32 kHz fixed frequency I2S clock
- Peripherals: Additionally, a subset of the peripherals can run on either the 16 MHz fixed frequency or the backplane clock

## 1.1.2 Reset

The Power Management Unit (PMU) releases the chip-wide reset once the power supplies have stabilized. There is no explicit reset pin on the ATM33 Series SoC but the user can use PWD for an equivalent purpose, and when used as a reset pulse, the PWD pulse duration should be 1 ms or longer, and higher than 700 mV during the pulse duration to trigger a reset. Many of the internal modules can additionally be reset through a software register write.

## 1.1.3 Power Modes

The SoC supports six primary power states which are Active, WFI, Retention, Hibernation, SoC Off, and Powerdown. Each primary state may have several secondary states depending on the number of active power domains and clock gating.

1. **Active:** All regions of the SoC are powered on. Active power can be optimized by utilizing clock gating registers and/or by putting the Cortex-M33F into Wait For Interrupt (WFI).
  - Bluetooth LE Deep Sleep: Bluetooth subsystem is powered down while the remainder of the ATM33 Series SoC is powered up. This state is useful when data needs to be processed but does not need to be transmitted over RF.
2. **WFI:** When the MCU is Idle, it can be placed into WFI state to conserve power.
3. **Retention:** All or some of the 128 KB SRAM, in increments of 16 KB, can be retained. All register/flip-flop states are retained. Digital I/O's will hold the state they were at when the transition into either Hibernate or Retain started. Wake can be from a timer expiring, activity detected on GPIO's, activity detected on the keyboard, activity detected on the mouse, the sensor hub reading measurements crossing a threshold, and the detection of a connection over the SWD interface. All selections about how to wake need to be programmed before the transition into the low power state is triggered. The SRAM supply voltage can be lowered to further reduce leakage power consumption.
4. **Hibernation:** Powers down system memory. Retains only a minimal amount of flip-flop state. Retains I/O state. Wake up setting must be programmed before transitioning into this state.
5. **SoC Off:** All digital domains including the top level digital domain are powered down, but the PMU remains on in an ultra low-power state with limited functionality. The system must do a complete, cold start reboot when returning from this state to an active state. Wake mechanisms are limited to
  - special 40-bit timer
  - external pin edge on P5
  - ultra-low power analog comparator with input on either P3 or P4.
6. **Powerdown (PWD pin asserted):** All power domains including the PMU are completely shut off. No supplies are internally generated or maintained.

## 1.2 Bluetooth LE Radio

The block diagram of the low-power radio is shown in [Figure 1.2-1](#). The radio supports 1 Mbps basic PHY, 2 Mbps high-speed PHY, 500 kbps and 125 kbps PHY. The basic 1 Mbps PHY is compatible with Bluetooth 4.0, while the 2 Mbps rate provides 2X speed and the long range rates provide up to 4X range.

The transmit path uses digital direct frequency modulation of a fractional-N synthesizer to create a constant amplitude GFSK signal that is amplified by a power amplifier to provide the desired RF output level.



On the receive path, an incoming RF signal is first amplified by an LNA before downconversion to baseband and digitized by two successive-approximation analog-to-digital converters. The digitized signal is sent to the modem for further digital processing.

The radio architecture is optimized for burst data transmission using Frequency-Hopping Spread Spectrum (FHSS) with 40 channels with 2 MHz spacing (3 advertising channels/37 data channels). Only a single RF Input/Output pin is needed, thereby simplifying board-level design. Bluetooth 5.1 AoA and AoD direction finding are supported.

**Figure 1.2-1 Bluetooth LE Radio Block Diagram**

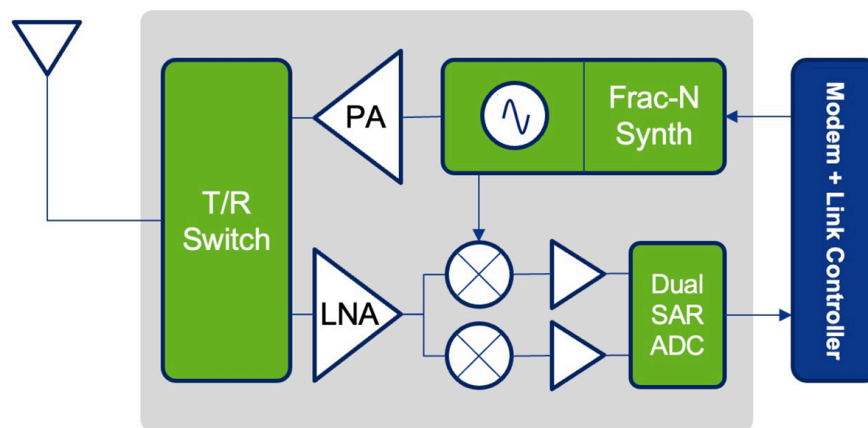

### 1.2.1 Link Controller

The Bluetooth 5.3 link controller (LC) and host stack provides an interface between the microcontroller (MCU), modem and exchange memory, allowing the MCU to access through the AHB bus to the control registers and exchange memory.

During transmit, software writes the packet payload and control structures into the exchange memory. The link controller serializes the data into a bit stream to the modem.

During receive, the operation is reversed. Received data from the modem is processed and stored in the exchange memory to be read by software.

The design runs on an 8 MHz clock and is synchronous to modem (16 MHz) and AHB bus (16 MHz) and exchange memory (16 MHz).

### 1.2.2 Modem

The modem, along with the radio, link controller and software stack, forms a highly efficient Bluetooth 5.3 solution. Transmission and reception supports AoA and AoD direction finding, and PHY rates of 2 Mbps, 1 Mbps, 500 kbps and 125 kbps are supported. The direction finding feature only supports 2  $\mu$ s slots.

During receive operation, the modem and radio are enabled prior to expected packet reception as determined by the link controller. Incoming packets are detected, tracked, processed, and then forwarded to the link controller. The modem and

radio receiver are turned off by the link controller at the end of a completed packet. Channel information is provided directly from the link controller to the radio without involvement of the modem.

There is minimal involvement of the modem in the transmit process. The link controller provides the symbol bit stream, which is then shaped consistent with the GFSK requirements to provide a frequency deviation for the radio. Channel information and target transmit power are provided directly from the link controller to the radio.

### 1.3 Wakeup Receiver

Figure 1.3-1 Wakeup Receiver Block Diagram

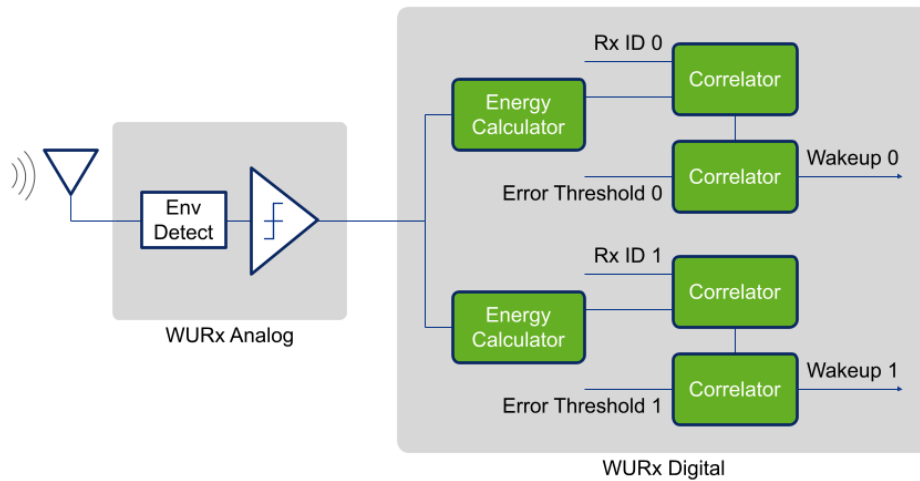

The use of the wakeup receiver (WURx) could further lower the power consumption. When enabled, the WURx allows the system to stay in sleep mode while listening to incoming RF signals without using the BLE radio. Only when the correct Rx ID is detected does the main radio turn on. This allows for a much lower power consumption since the WURx circuit uses very little power and much less than the BLE radio. In the case of ATM33, it uses only about 400 nA. And because the WURx is always listening, it allows for low latency. Latency of the wakeup receiver is typically in the order of 20 ms to 1 s, depending on the length of the Rx ID code used to identify the target device. Sensitivity is -55 to -60 dBm depending on the power consumption setting. WURx is intended for short range.

WURx is an OOK (On-Off Keying) receiver and uses an envelope detector to find specific patterns in the incoming signal. The best way to generate the ID is to use an OOK transmitter. The pattern of the OOK signal, will correspond to a stream of ones and zeros that the digital part of WURx would check against the Rx ID it is expecting. If transmitting a custom OOK signal isn't possible, any RF signal with the right RF frequency can be used as an OOK signal as long as its length and duty cycle is suitable to match a reasonable ID when the envelope is sampled by a 32KHz clock. Some examples of available RF sources are iBeacon or BT inquiry. ATM33 can check for two completely different Rx IDs simultaneously. This is especially useful when listening to access points that could be either iOS or Android.

WURx is optimized to operate in the 2.4 GHz Bluetooth frequency band so that it can respond to a wakeup signal based on Bluetooth advertising packets. However, the wakeup receiver can work anywhere from 400 MHz to 2.5 GHz if the RF front end match is appropriately modified.

WURx is available on the 7x7 QFN 56 pin package.

## 1.4 Power Management Unit (PMU)

The power management unit provides the core and I/O power supplies to the ATM33 Series SoC.

PMU generates three power supply outputs: DVDD1P, AVDD1P, VDDIOP, and a fourth auxiliary supply VAUX used internally by the PMU. The following connections must be made on the board:

- DVDD1P to DVDD1
- AVDD1P to AVDD1

**Table 1.4-1 PMU External Pins**

Pin	Description
VBAT	Battery input Battery voltages from 1.1 V to 3.3 V can be used. Must connect to a 10 $\mu$ F capacitor if VBATLI is used.
VBATLI	Lithium ion battery input in place of VBAT 2.7 to 4.2 V lithium ion battery supply. If lithium ion battery is not used, it is recommended to connect this pin to VBAT.
VDDPA	PA power supply
LEXT1, LEXT2	Terminals between which the switching regulator inductor is connected.
DVDD1P, AVDD1P VDDIOP	DVDD1P and AVDD1P are PMU generated digital and analog core supply outputs. VDDIOP is a PMU generated 1.8 V I/O supply output.
VAUX	Auxiliary supply output of typical value 3.2 V, used internally by the PMU.
DVDD1, AVDD1	Power supply input for digital and analog core circuits.
VDDIO	Power supply input for digital and analog I/O circuits.

The PMU provides multiple brownout interrupts to enable more reliable operation.

### 1.4.1 PMU Configurations

The PMU must be configured correctly to ensure correct operation. The following modes of operation are supported by the PMU:

PMU Configuration	VBAT Connection	VBATLI Connection	VDDIO Connection
Battery or external power supply (1.1 V-3.3 V) with internally generated I/O supply	Battery or power supply	VBAT	VDDIOP
Battery or external power supply (1.8 V-3.3 V) with externally generated I/O supply	Battery or power supply	VBAT	VBAT or other externally generated I/O supply that is between 1.8 V-3.3 V.
High Voltage battery or power source (2.7 V-4.2 V) with internally generated I/O supply	Unconnected (keep bypass capacitor connected)	High voltage battery or power source	VDDIOP

## 1.5 Security

The ATM33 Series SoC offers a complete security solution including:

- Secure boot
- Secure Firmware Update
- Secure execution
- Key management
- Key storage
- Secure debugging

The ATM33 Series SoC has a true random number generator (TRNG) which generates a single 32 bit random number per invocation. Arbitrarily long random numbers can be achieved by repeatedly invoking this random number generator. The TRNG can also be used to seed the hash function.

The ATM33 Series SoC also has two hardware cryptographic accelerators, AES-128/256 and SHA-2/HMAC 256 which are both accessible by software. There are provisions to load keys into the AES-128/256 where the keys themselves are not readable by any bus master.

## 1.6 Sensor Hub

The sensor hub is operational while the rest of the SoC is in hibernation. The sensor hub can be programmed to collect sensor data via SPI or I2C and store them to the external Flash or a region in RAM periodically until the total collected data reaches a predetermined amount. SoC can then wake up and transmit the data via Bluetooth. In addition, the core can be programmed to manage the link controller to send simple Bluetooth LE advertisements in timer-based periodicity.

## 1.7 OTP Access

The 64-bit one time programmable memory (OTP) is used to store PMU battery configurations during the start up process. The OTP is accessible through the Advanced Peripheral Bus (APB) once the MCU is up and running and provides indirect access for byte reads and bit writes.

VAUX will need to be set to the 2.5 V setting before OTP bits are written. Reads can happen at any voltage.

## 1.8 Timers and Interrupts

### 1.8.1 Wakeup Timer

Wakeup timer is a 40-bit timer based on the low power 32 kHz clock. When this timer is enabled during SoC Off mode, it will determine the SoC off duration.

### 1.8.2 General Purpose Timers

There are four (4) general purpose timer cores: Timer0, Timer1, Dual Timer, and Slow Timer. The values of the timers are readable by the MCU. All timers are clocked by the medium power clock except for the Slow Timer which uses the low power clock. All these timers stop when the system enters a low power mode. The state of the timer is maintained during retention mode but is reset during hibernate mode.

- Timer0, if enabled, will decrement from a 32-bit reload value to 0 triggering a maskable interrupt as it transitions from 1 to 0. The reload value is loaded as the next timer value when the timer reaches 0.
- Timer1 is identical to Timer0 with its own register space and its own interrupt.
- Dual Timer contains two timers and each timer is independent of the other but sharing a single interrupt output. Each timer counts down and can run in one-shot, periodic, or free running mode. The timers are configurable to be either 16 bit or 32 bit. Additionally there is a prescaler in front of each timer that can reduce the incoming clock by 1x (no change), 16x, or 256x.
- Slow Timer is a 40-bit count down timer with three programmable thresholds. The interrupt is optionally asserted when the counter counts from one above the threshold to the threshold. It is recommended that the timer be read twice and the value used only if the values from both reads are the same. If the values are not the same then the read should happen a third time. The timer is updated every 16000000/32768 cycles or approximately 488 cycles of the 16 MHz medium power clock.

### 1.8.3 Interrupts

The SoC supports the following categories of interrupts:

- Interrupts for ARM MCU exceptions, watchdog timers, and hardware protection blocks.
- Maskable Interrupts for Peripherals:
  - 28 interrupts for APB peripherals
  - 4 DMA interrupts
  - 12 Bluetooth LE interrupts
  - 1 power sequencer interrupt
  - 31 GPIO interrupts (ATM3330 56-pin QFN, 7x7 mm), 21 GPIO interrupts (ATM3325 40-pin QFN, 5x5 mm), 18 GPIO interrupts (ATM3325 40-pin QFN, 5x5 mm, with extended storage), 21 GPIO interrupts (ATM3325 49L WLCSP)

## 1.9 Peripherals and I/O

The following peripherals are supported by the SoC.

- **GPIO**

There are up to 31 GPIOs available on the ATM3330 7x7 mm QFN package, up to 21 GPIOs in the ATM3325 5x5 mm QFN package, up to 18 GPIOs in the ATM3325 5x5 mm QFN package with extended storage, and up to 21 GPIOs available on the ATM3325 49L WLCSP package. GPIOs are controlled through software accessible registers. In addition to drive, sample, pull up and pull down functions, the GPIO can also be used to generate interrupts and to wake the ATM33 Series SoC from low power states.
- **I2C**

There are two identical I2C cores that support master mode. In master mode, software preloads the transaction and then initiates the hardware controller. Software can either poll for completion or respond to the completion interrupt. I2C clock speed is programmable to specific rates between 3.9 kHz to 2 MHz. The I2C cores do not support clock stretching.
- **Serial Peripheral Interface (SPI)**

There are two identical SPI master and slave cores. In master mode, software can preload the transaction, initiate it, and then either poll for completion or respond to the completion interrupt. Opcode, transaction type, data, and number of bytes are all software programmable. The hardware will serialize and sample incoming data as required by the protocol. The SPI port clock frequency is programmable to specific rates between 7.8 kHz to 8 MHz. One SPI core in slave mode can wake up the SoC from a low power state.
- **Quad Serial Peripheral Interface (QSPI)** supports external flash up to 32 MHz  
There is one quad SPI master port and it is intended to be connected to embedded extended flash storage or an external flash (if needed). Internally there are three cores that can act as master for the interface:
  - (a) 1-bit core identical to the SPI core described previously. It provides read and write support to the external flash via indirect addressing.
  - (b) Software specified protocol / content. The hardware's role is limited to serial shift in or out. Read and write access via indirect addressing is provided by this core.
  - (c) Direct memory mapping of the entire external flash contents. It essentially acts as an AHB bridge to the external flash. The hardware handles all protocols. Additionally this core contains a cache in the read direction to reduce latency.
- **UART**

There are two UART cores with flow control present on the ATM33. UART0 should be used for HCI type applications and UART1 primarily for debug messaging (without flow control).
- **PDM**

The PDM provides digital microphone support with programmable clock rates from 500 kHz to 4 MHz. It supports a stereo mode with left and right channels multiplexed on the same data line with the rising and falling edges of the clock. The PDM-to-PCM conversion takes a 1-bit PDM output from a digital microphone as input, and outputs a PCM signal with programmable bit width of 16/20/24-bit. The PCM sample rate is programmable (6/8/12/16 kHz) with programmable filter BWs. The low pass filtering for these provides an out-of-band attenuation of 60 dB. Additional sample rates of 24, 32, 48 and 64 kHz are available with limited filtering. The IIR filter in the signal path, which attenuates any residual DC content, has programmable order (1st, 2nd or 3rd) and bandwidth (10 Hz to 2 kHz). There is a digital gain control block with programmable gain from -30 dB to 30 dB in steps of 0.5 dB.

The output from the PDM-to-PCM core is captured in FIFO. There are two separate sets of FIFO arrays for APB, and AHB (faster) access:

1. APB 16-entry FIFO which overruns if not drained quickly.
2. AHB FIFO supports a 64 x 32 ping-pong buffer. 64 entries are split into 4 arrays, bufferA to bufferD. PDM outputs are written starting at bufferA. Each entry is 32-bit which can be two 16-bit audio samples or single 20/24-bit samples with options for packing and swapping samples. AHB access is faster and data can be transferred into SRAM or NVM using direct memory access (DMA) based on application.

- **I2S**

I2S is designed to support inter-IC sound bus for transporting digital audio data streams. This interface consists of:

- SCK - system clock or bit clock or serial clock
- WS - word select or frame clock or left/right clock
- SD - serial data or data line

Depending on how the module is configured as transmitter or receiver and as master or slave, the module sources or sinks these interface signals based on the configuration. Supported operation modes are PCM mode, left-justified mode and right-justified mode.

- **PWM**

The PWM has eight independent pulse width modulation output channels. Each channel can operate in one of four modes:

1. Continuous mode - The user specifies the duty cycle and the PWM channel outputs perpetuity.
2. Counting mode - The user specifies the number of times to repeat in addition to duty cycle. This combination of duty cycle and repeat count is referred to as a frame.
3. IR mode - The PWM channel outputs one frame type and, immediately on completion of the first frame, outputs a second frame. This second frame can be identical to the first or it can be different if a different set of parameters were loaded in while the first frame was going out.
4. IR FIFO mode - The PWM core pulls the next frame information from a FIFO. One FIFO buffer is time-shared among all eight channels, therefore IR FIFO mode is only supported in the channel equipped with the FIFO buffer.

All channels support all modes of operation.

PWM frequency ranges from 122 Hz to 10 MHz with 16 bit fields to independently control high duration and low duration.

- **Quadrature Decoder (QDEC)**

The QDEC is a 3-axis (x,y,z) quadrature decoder. Each axis is independent and requires 2 input pins. QDEC continuously updates the internal integrators and their values can be read by software.

- **Keyboard Scan Matrix (KSM) Controller**

The KSM is a keyboard scanner which supports up to 8 rows by 20 columns or 20 rows by 8 columns. Key pressed and key released events can optionally require that the key be pressed or be released across multiple consecutive scans. Up to 12 simultaneous key events can be tracked.

A portion of the KSM can continue to scan during low power states. The key-pressed or key-released event can also optionally wake the ATM33 Series SoC from a low power state. Key events are not lost when the ATM33

Series SoC is in a low power state. Key events are packetized and written into a FIFO via the hardware for later reading by the software. KSM controller pins can be reverted to GPIO if KSM features are not used.

- **Analog Comparator**

A 16-level analog comparator provides an ultra-low power approach to sense an analog input signal from sensors.

- **Application ADC**

11-bit Application ADC, also known as General-purpose ADC (GADC), with 4 external channels (can be configured as two differential channels, four single-ended channels or a combination of one differential channel with two single-ended channels), and 5 internal channels (battery, energy storage element, core supply, temperature, Li-ion battery). The sample rate is 2 Msps divided across the number of multiple channels used.

## 1.10 Pin Multiplexing

The ATM3330 7x7 mm, 56-pin QFN package supports up to 31 programmable I/O pins that could be connected to multiple functional signals. The ATM3325 5x5 mm, 40-pin QFN package supports up to 21 programmable pins. The ATM3325 5x5 mm, 40-pin QFN package with extended storage supports up to 18 programmable pins. The ATM3325 49L WLCSF package supports up to 21 programmable pins.

In addition, each of these I/O pins can be configured to be input only, output only, input/output, with or without a pull-up. A pin multiplexing tool provided in the SDK can be used to program the I/Os to the desired function.



## 2 Electrical Specification

All parameters' typical values are based on 3 V supply at 25 °C unless otherwise specified, and if specified, min/max values are based on the worst case process variation, voltage, and ambient temperature conditions. Radio parameters are measured using a conducted configuration.

**Table 2-1 Maximum Electrical Ratings**

Maximum Ratings					
Symbol	Parameter	Min	Typ	Max	Unit
VBAT	Battery supply	-0.2		3.6	V
	Voltage ramp rate	0.01			V/ms
VBATLI	Lithium ion battery supply	2.4		4.6	V
	Voltage ramp rate	0.01			V/ms
AVDD	Analog core voltage	-0.2		1.3	V
DVDD	Digital core voltage	-0.2		1.3	V
VDDPA	PA supply	-0.2		3.6	V
VSTORE	Storage element	-0.2		3.6	V
VDDIO	I/O supply	-0.2		3.6	V
VAUX	PMU Auxiliary Supply	-0.2		3.6	V
VIO	I/O pin (VDDIO > 3.4 V)	-0.2		3.6	V
	I/O pin (VDDIO ≤ 3.4 V)	-0.2		VDDIO+0.2	
VRF	RF I/O pin			10	dBm
	DC Voltage			1.8	V
VRFIN	WURX RF IN pin			-10	dBm
ESD <sub>HBM</sub>	ESD HBM			2000	V
ESD <sub>CDM</sub>	ESD CDM			500	V
T <sub>STORE</sub>	Storage Temperature	-40		125	°C
T <sub>j</sub>	Junction Temperature			125	°C

**Table 2-2 Recommended Operating Conditions**

Recommended Operating Conditions					
Symbol	Parameter	Min	Typ	Max	Unit
T <sub>j</sub>	Junction Temperature			125	°C
VDDIO <sup>1</sup>	I/O supply	1.65	1.8	3.3	V
VBAT <sup>2</sup>	Battery supply	1.1		3.3	V
VBATLI	Lithium ion battery supply	2.7		4.2	V
VDDPA	PA supply	1.0	1.8	1.89	V
VAUX	PMU Auxiliary Supply	2.5	3.3	3.3	V
VIO	I/O pin	0		VDDIO+0.2	V
	Crystal (Tolerance + Stability) - 16.000 MHz	-50		50	ppm
	Crystal (Tolerance + Stability) - 32.768 kHz	-500		500	ppm
TA	Operating (Ambient) Temperature	-40	25	85	°C

<sup>1</sup> VDDIO: Refer to the ATM33/e Series Reference Manual ‘PMU Configurations’ section for valid configurations in conjunction with VBAT/VBATLI.

<sup>2</sup> VBAT: Refer to the Battery Level section of the ATM33/e Series Reference Manual ‘PMU Configurations’ section for OTP or register settings that may limit this range.

**Table 2-3 Radio Transceiver Characteristics**

Parameter	Conditions	Min	Typ	Max	Unit
Supported PHY Rate	1M uncoded		1M		bps

Parameter	Conditions	Min	Typ	Max	Unit
	2M uncoded 500k coded 125k coded		2M 500k 125k		bps bps bps
Frequency		2.402		2.480	GHz
Rx sensitivity RFPHY/RCV/BV-01-C, PER=30%	37-byte packets, clean Tx  125 kbps 500 kbps 1 Mbps 2 Mbps  255-byte packets, dirty Tx  125 kbps 500 kbps 1 Mbps 2 Mbps		-101 -98 -95 -92  -100 -96 -93 -90		dBm dBm dBm dBm  dBm dBm dBm dBm
Tx output power RFPHY/TRM/BV-01-C	Typical levels: 10,8,6,4,2,0,-2,-4,-6,-8,-10,-20	-20		10	dBm
Tx power accuracy			+/-1.5		dB
Tx spectral mask @ 1M sym/s RFPHY/TRM/BV-03-C	2 MHz offset  > 3 MHz offset	-20  -30			dBm dBm
Rx Carrier-to-Interferer (Bluetooth LE 1M PHY) RFPHY/RCV/BV-03-C	Co-channel interference Adjacent 1 MHz interference Adjacent 2 MHz interference Adjacent 3 MHz interference	21 15 -17 -27			dB dB dB dB
RSSI resolution			1		dB
RSSI accuracy	-90 to -20 dBm		+/-2		dB

**Table 2-4 Wakeup Receiver Characteristics**

Wakeup Receiver Characteristics					
Parameter	Conditions	Min	Typ	Max	Unit
Sensitivity <sup>1</sup>	2440 MHz, 14-byte packets at 1 ms interval for 40 ms		-54		dBm
	900 MHz, 14-byte packets at 1 ms interval for 40 ms		-58		dBm

**Table 2-5 PMU Characteristics**

PMU Characteristics					
Parameter	Conditions <sup>2</sup>	Min	Typ	Max	Unit
AVDD1P Output Voltage	10uF at output pin, connected to AVDD1	0.950	1.0	1.050	V
DVDD1P Output Voltage	10uF at output pin, connected to DVDD1	0.750	1.1	1.150	V
VDDIOP Output Voltage	1uF at output pin, connected to VDDIO and VDDPA	1.65	1.8	1.94	V
VAUX Output Voltage	4.7uF at output pin	3.0	3.2	3.5	V

<sup>1</sup> Values in this table do not include the effects of switching regulator ripple, and are measured using an SDK app in idle mode, or in hibernate mode.

<sup>2</sup> Conditions include any additional bypass cap or filter on the load end (AVDD1, DVDD1, etc)

<sup>1</sup> >= 90% wakeup success rate

**Table 2-6 GPIO Characteristics**

Parameter	Conditions	Min	Typ	Max	Unit
Input VIH		VDDIO * 0.7			V
Input VIL				VDDIO * 0.3	V
Output VOH	2 mA Load, PDSN=0 VDDIO = 3.3 V		3.27		V
	VDDIO = 1.8 V		1.76		V
	2 mA Load, PDSN=1 VDDIO = 3.3 V		3.25		V
	VDDIO = 1.8 V		1.71		V
Output VOL	2 mA Load, PDSN=0 VDDIO = 3.3 V		0.02		V
	VDDIO = 1.8 V		0.03		V
	2 mA Load, PDSN=1 VDDIO = 3.3 V		0.04		V
	VDDIO = 1.8 V		0.06		V
Drive Strength, push-pull high	VPIN=VDDIO-0.3 V VDDIO = 3.3 V, PDSN=0		21		mA
	VDDIO = 3.3 V, PDSN=1		11		mA
	VDDIO = 1.8 V, PDSN=0		12		mA
	VDDIO = 1.8 V, PDSN=1		6		mA
Drive Strength, push-pull low	VPIN is 0.3 V VDDIO = 3.3 V, PDSN=0		27		mA

Parameter	Conditions	Min	Typ	Max	Unit
	VDDIO = 3.3 V, PDSN=1		14		mA
	VDDIO = 1.8 V, PDSN=0		17		mA
	VDDIO = 1.8 V, PDSN=1		8		mA
Pull-up Resistance			125		kΩ

**Table 2-7 Application ADC Characteristics**

Application ADC Characteristics					
Parameter	Conditions	Min	Typ	Max	Unit
Resolution			11		bits
Effective Number of Bits			9		bits
Sampling Rate	Raw, one channel		2		MS/s
	SDK driver		1		ms
Input Signal Range	VDDIO = 3.3 V	0		3.2	V
	VDDIO < 3.3 V	0		VDDIO	
Reference Voltage			1		V
SNDR			55		dB
INL <sup>1</sup>			3		LSB
DNL <sup>1</sup>			3		LSB
Input capacitance	External Channels, 2 MHz input signal <sup>2</sup>		400		fF
Channel Switching Time			31		μs
Conversion Time	Using SDK driver		900		μs
Measurement Accuracy	Temperature		±17		°C
	Voltage (Single Channel)		±10		mV
	Voltage (Differential Channel)		±20		mV
	Li-ion Battery		±20		mV

<sup>1</sup> Measurement with gain\_sel=0, external single channel

<sup>2</sup> External channels on P4-P7 may have extra capacitance due to PCB design.

**Table 2-8 Radio Power Consumption**

<b>Radio Power Consumption</b> VBAT current at 3 V with internally or externally generated I/O supply					
Parameter	Conditions	Min	Typ	Max	Unit
Radio Receiver Rx	Sensitivity at -95 dBm  All Rates, max gain, search, or data reception.		0.85		mA
Radio Transmitter Tx	Output power at 0 dBm		2.5		mA

**Table 2-9 SoC Power Consumption (3 V)**

<b>SoC Power Consumption</b> VBAT current at 3 V with internally generated I/O supply  (Active RX and Active Tx SoC Power Consumption includes Radio Power Consumption)					
Parameter	Conditions	Min	Typ	Max	Unit
Active RX	All Rates, max gain search, or data demodulation		1.4		mA
Active TX	Output power at				
	10 dBm		12.9		mA
	8 dBm		9.3		mA
	6 dBm		8.2		mA
	4 dBm		4.2		mA
	2 dBm		3.4		mA
	0 dBm		3.0		mA
	-2 dBm		2.7		mA
	-4 dBm		2.4		mA
	-6 dBm		2.1		mA
	-8 dBm		1.8		mA
-10 dBm		1.6		mA	
-20 dBm		1.2		mA	
MCU Active (16 MHz)	Executing CoreMark from RAM at 16 MHz		0.9		mA
MCU Active (64 MHz)	Executing CoreMark from RAM at 64 MHz		2.8		mA

MCU Idle + Bluetooth LE Deep Sleep		0.5		mA
Retention	0 KB RAM (None)	1.8		μA
	32 KB RAM	1.8		μA
	128 KB RAM (Full)	2.1		μA
Hibernation		1.3		μA
Hibernation with Wakeup Receiver		1.6		μA
SoC Off		400		nA
Powerdown	PWD pin asserted	120		nA

Note: For a detailed description of low power consumption modes, refer to “Understanding Low Power Modes for ATM33/e Series”

**Table 2-10 SoC Power Consumption (4.2 V)**

<b>SoC Power Consumption</b>					
<b>VBATLI current at 4.2 V with internally generated I/O supply</b>					
(Active RX and Active Tx SoC Power Consumption includes Radio Power Consumption)					
Parameter	Conditions	Min	Typ	Max	Unit
Active RX	All Rates, max gain search, or data demodulation		1.4		mA
Active TX	Output power at				
	10 dBm		13		mA
	8 dBm		9.3		mA
	6 dBm		8.0		mA
	4 dBm		4.0		mA
	2 dBm		3.4		mA
	0 dBm		3.0		mA
	-2 dBm		2.7		mA
	-4 dBm		2.4		mA
	-6 dBm		2.1		mA
	-8 dBm		1.8		mA
	-10 dBm		1.6		mA
-20 dBm		1.2		mA	



MCU Active (16 MHz)	Executing CoreMark from RAM at 16 MHz		0.9		mA
MCU Active (64 MHz)	Executing CoreMark from RAM at 64 MHz		2.9		mA
MCU Idle + Bluetooth LE Deep Sleep			0.5		mA
Retention	0 KB RAM (None)		2.1		μA
	32 KB RAM		2.1		μA
	128 KB RAM (Full)		2.4		μA
Hibernation			1.6		μA
Hibernation with Wakeup Receiver			1.9		μA
SoC Off			900		nA
Powerdown	PWD pin asserted		400		nA

Note: For a detailed description of low power consumption modes, refer to “Understanding Low Power Modes for ATM33/e Series”

Table 2-11 NVM/RRAM Characteristics

Symbol	Parameter	Min	Typ	Max	Unit
VDDIO		1.62	1.8	3.6	V
Write Endurance		10K			Cycles
Data Retention		10			Years
Read Cycle (4-bytes)	Current (@1.8 V)		0.35		mA
	Duration		0.400		μs
Write Cycle (4-bytes) Pattern: 0xaa->0x55	Current (@1.8 V)		4.6		mA
	Duration		180		μs

Table 2-12 Flash (Extended Storage) Characteristics

Symbol	Parameter	Min	Typ	Max	Unit
Endurance	Program / Erase	100 K			Cycles

---

Data Retention			20		Years
Page Program Time			1		ms
Sector Erase Time			100		ms

### 3 Pinout Description

#### 3.1 ATM3330-5DCAQN 7x7 mm, 56-pin QFN Pinout

The ATM3330 7x7 mm version is packaged in a 56-pin Quad Flat Package No Leads (QFN). The pin assignment is shown in [Table 3.1-1](#). All pins are on the bottom side of the package.

Figure 3.1-1 ATM3330-5DCAQN 7x7 mm, 56-Pin QFN Pinout (Top View)

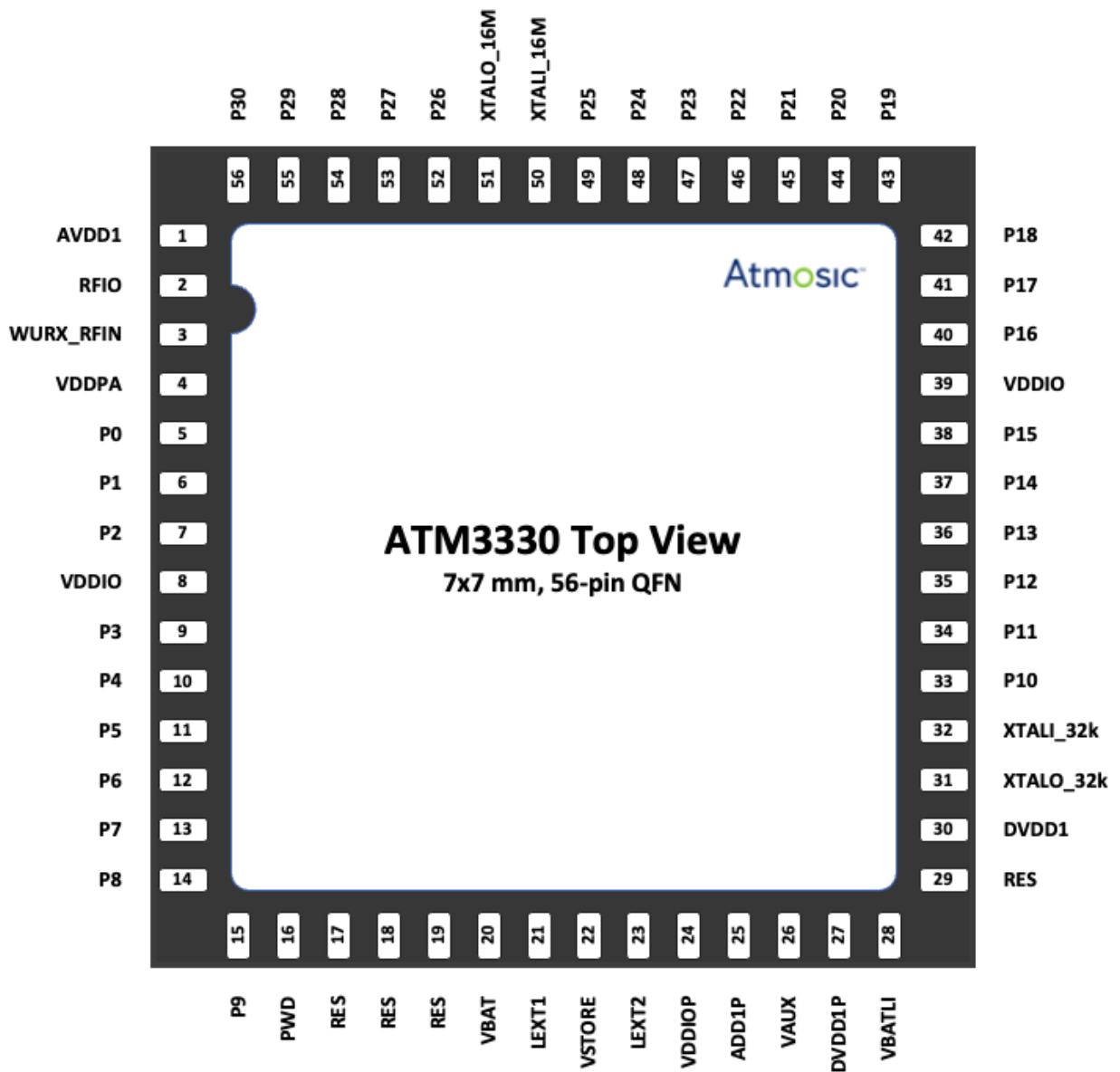

Pin Type Definitions	
Pin Type	Definition
I/O	Signal Input or Output
RF	Radio Frequency
PWR	Power supply
A	Analog
R	Reserved
NC	No connection, must be open
GND	Ground

Table 3.1-1 ATM3330-5DCAQN 7x7 mm, 56- Pin QFN Pin Description

ATM3330 7x7 mm, 56-Pin QFN Pin Description			
Pin Number	Name	Type	Description
1	AVDD1	PWR	Analog core power supply
2	RFIO	RF	2.4 GHz Single-ended RF I/O for Bluetooth radio
3	WURX_RFIN	RF	Wakeup receiver RF input
4	VDDPA	PWR	PA power supply
5	P0	I/O	Programmable Digital I/O
6	P1	I/O	Programmable Digital I/O
7	P2	I/O	Programmable Digital I/O
8	VDDIO	I/O	Digital I/O Power Supply
9	P3	I/O	Programmable Digital I/O or Analog Input
10	P4	I/O	Programmable Digital I/O or Analog Input
11	P5	I/O	Programmable Digital I/O or Analog Input
12	P6	I/O	Programmable Digital I/O or Analog Input
13	P7	I/O	Programmable Digital I/O or Analog Input
14	P8	I/O	Programmable Digital I/O
15	P9	I/O	Programmable Digital I/O
16	PWD	I/O	Power Down Input (Active High)
17	RES	R	Reserved, must tie to ground
18	RES	R	Reserved, must tie to ground
19	RES	R	Reserved, must tie to ground
20	VBAT	PWR	Battery supply. Must connect to 10 $\mu$ F capacitor if VBATLI is used.
21	LEXT1	A	Switcher Inductor
22	VSTORE	PWR	Optional power supply, connect to VDDPA for better TX efficiency, otherwise tie to ground if not used

23	LEXT2	A	Switcher Inductor
24	VDDIOP	PWR	1.8 V I/O power supply generated by switcher, connect to VAUX if unused
25	AVDD1P	PWR	1 V Analog and RF core power supply generated by switcher
26	VAUX	PWR	Reserved for switching regulator internal use
27	DVDD1P	PWR	1 V Digital core power supply generated by switcher
28	VBATLI	PWR	2.7 V to 4.2 V lithium ion battery supply in place of VBAT. If lithium ion battery is not used, this pin is recommended to be connected to VBAT.
29	RES	R	Reserved, must tie to ground.
30	DVDD1	PWR	1 V Digital core power supply
31	XTALO_32k	A	32.768 kHz crystal oscillator output
32	XTALI_32k	A	32.768 kHz crystal oscillator input
33	P10	I/O	Programmable Digital I/O
34	P11	I/O	Programmable Digital I/O
35	P12	I/O	Programmable Digital I/O
36	P13	I/O	Programmable Digital I/O
37	P14	I/O	Programmable Digital I/O
38	P15	I/O	Programmable Digital I/O
39	VDDIO	PWR	Digital I/O Power Supply
40	P16	I/O	Programmable Digital I/O
41	P17	I/O	Programmable Digital I/O
42	P18	I/O	Programmable Digital I/O
43	P19	I/O	Programmable Digital I/O
44	P20	I/O	Programmable Digital I/O
45	P21	I/O	Programmable Digital I/O
46	P22	I/O	Programmable Digital I/O
47	P23	I/O	Programmable Digital I/O
48	P24	I/O	Programmable Digital I/O
49	P25	I/O	Programmable Digital I/O, a weak pull low is required during MCU boot.
50	XTALI_16M	A	16 MHz crystal oscillator input
51	XTALO_16M	A	16 MHz crystal oscillator output
52	P26	I/O	Programmable Digital I/O
53	P27	I/O	Programmable Digital I/O
54	P28	I/O	Programmable Digital I/O
55	P29	I/O	Programmable Digital I/O
56	P30	I/O	Programmable Digital I/O
EPAD	VSS	GND	Ground supply for all circuits. The 56-pin QFN package has an exposed die pad (E-PAD) at its base. This E-PAD must be soldered to VSS.

### 3.2 ATM3325-5DCAQK 5x5 mm, 40-pin QFN Pinout

The ATM3325 5x5 mm version is packaged in a 40-pin Quad Flat Package No Leads (QFN). The pin assignment is shown in [Table 3.2-1](#). All pins are on the bottom side of the package.

Figure 3.2-1 ATM3325-5DCAQK 5x5 mm, 40-Pin QFN Pinout (Top View)

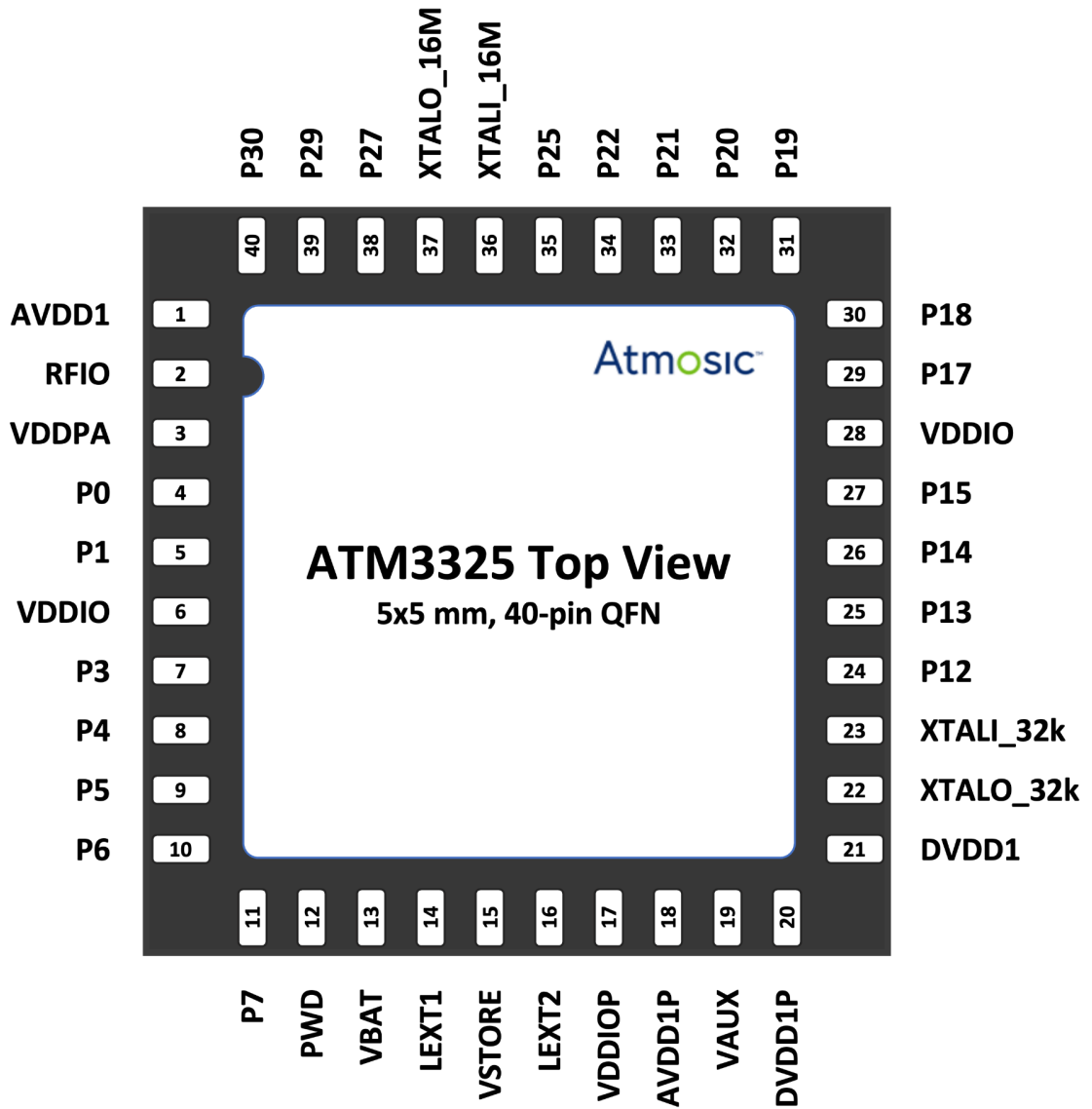

Pin Type Definitions	
Pin Type	Definition
I/O	Signal Input Output
RF	Radio Frequency
PWR	Power supply
A	Analog
R	Reserved
NC	No connection, must be open
GND	Ground

**Table 3.2-1 ATM3325-5DCAQK 5x5 mm, 40-pin QFN Pin Description**

ATM3325 5x5 mm, 40-pin QFN Pin Description			
Pin Number	Name	Type	Description
1	AVDD1	PWR	Analog core power supply
2	RFIO	RF	2.4 GHz Single-ended RF I/O for Bluetooth radio
3	VDDPA	PWR	PA power supply
4	P0	I/O	Programmable Digital I/O
5	P1	I/O	Programmable Digital I/O
6	VDDIO	I/O	Digital I/O Power Supply
7	P3	I/O	Programmable Digital I/O or Analog Input
8	P4	I/O	Programmable Digital I/O or Analog Input
9	P5	I/O	Programmable Digital I/O or Analog Input
10	P6	I/O	Programmable Digital I/O or Analog Input
11	P7	I/O	Programmable Digital I/O or Analog Input
12	PWD	I/O	Power Down Input (Active High)
13	VBAT	PWR	Battery supply.
14	LEXT1	A	Switcher Inductor
15	VSTORE	PWR	Optional power supply, connect to VDDPA for better TX efficiency, otherwise tie to ground if not used.
16	LEXT2	A	Switcher Inductor
17	VDDIOP	PWR	1.8 V I/O power supply generated by switcher, connect to VAUX if unused.
18	AVDD1P	PWR	1 V Analog and RF core power supply generated by switcher
19	VAUX	PWR	Reserved for switching regulator internal use
20	DVDD1P	PWR	1 V Digital core power supply generated by switcher
21	DVDD1	PWR	1 V Digital core power supply
22	XTALO_32k	A	32.768 kHz crystal oscillator output
23	XTALI_32K	A	32.768 kHz crystal oscillator input

24	P12	I/O	Programmable Digital I/O
25	P13	I/O	Programmable Digital I/O
26	P14	I/O	Programmable Digital I/O
27	P15	I/O	Programmable Digital I/O
28	VDDIO	I/O	Digital I/O Power Supply
29	P17	I/O	Programmable Digital I/O
30	P18	I/O	Programmable Digital I/O
31	P19	I/O	Programmable Digital I/O
32	P20	I/O	Programmable Digital I/O
33	P21	I/O	Programmable Digital I/O
34	P22	I/O	Programmable Digital I/O
35	P25	I/O	Programmable Digital I/O, a weak pull low is required during MCU boot.
36	XTALI_16M	A	16 MHz crystal oscillator input
37	XTALO_16M	A	16 MHz crystal oscillator output
38	P27	I/O	Programmable Digital I/O
39	P29	I/O	Programmable Digital I/O
40	P30	I/O	Programmable Digital I/O
EPAD	VSS	GND	Ground supply for all circuits. The 40-pin QFN package has an exposed die pad (E-PAD) at its base. This E-PAD must be soldered to VSS.



### 3.3 ATM3325-5LCAQK 5x5 mm with Extended Storage, 40-pin QFN Pinout

The ATM3325 5x5 mm with extended storage version is packaged in a 40-pin Quad Flat Package No Leads (QFN). The pin assignment is shown in [Table 3.3-1](#). All pins are on the bottom side of the package.

Figure 3.3-1 ATM3325-5LCAQK 5x5 mm with Extended Storage, 40-Pin QFN Pinout (Top View)

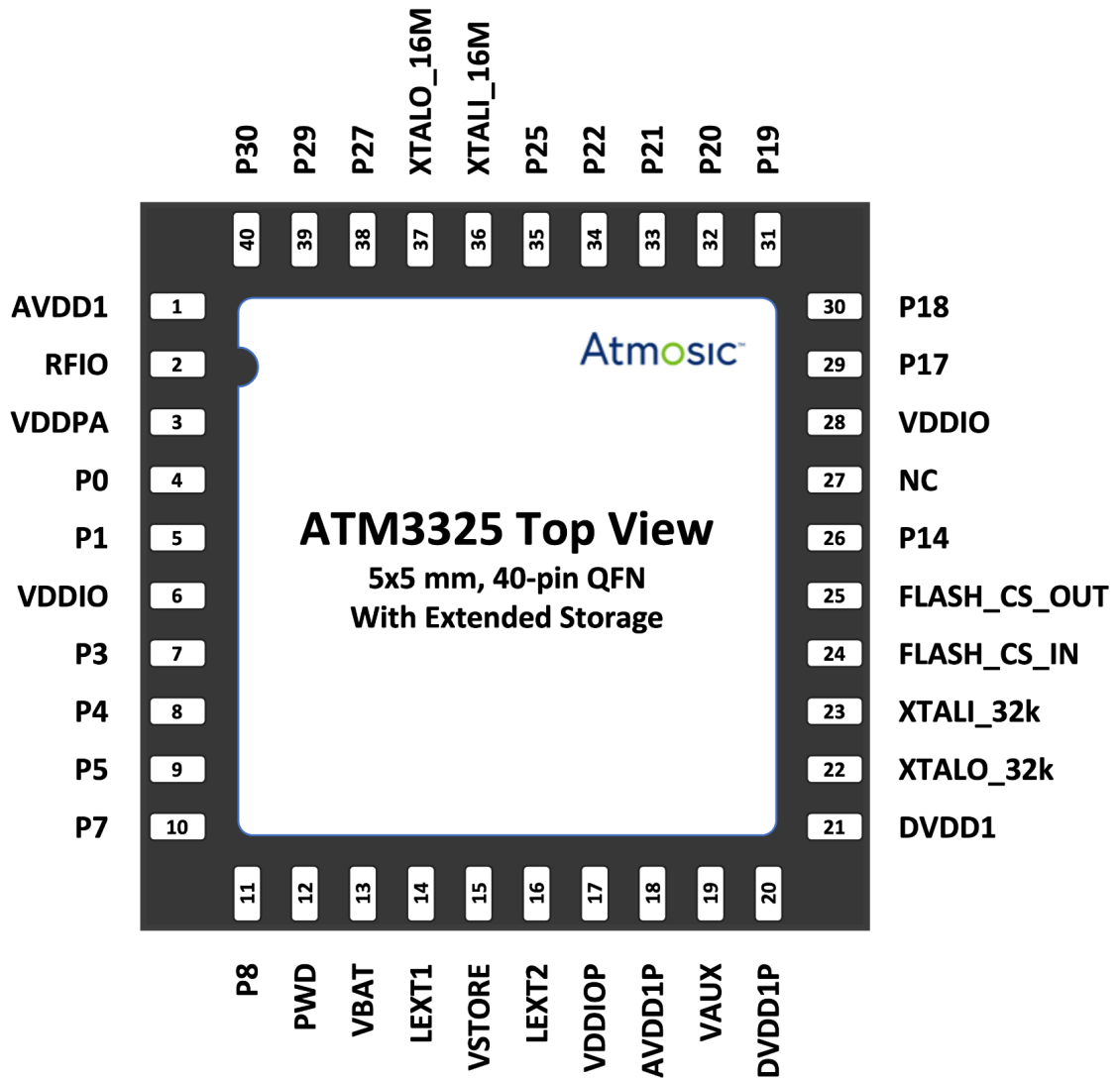

Pin Type Definitions	
Pin Type	Definition
I/O	Signal Input Output
RF	Radio Frequency
PWR	Power supply
A	Analog
R	Reserved
NC	No connection, must be open
GND	Ground

**Table 3.3-1 ATM3325-5LCAQK 5x5 mm, 40-pin QFN with Extended Storage Pin Description**

ATM3325 5x5 mm, 40-pin QFN with Extended Storage Pin Description			
Pin Number	Name	Type	Description
1	AVDD1	PWR	Analog core power supply
2	RFIO	RF	2.4 GHz Single-ended RF I/O for Bluetooth radio
3	VDDPA	PWR	PA power supply
4	P0	I/O	Programmable Digital I/O
5	P1	I/O	Programmable Digital I/O
6	VDDIO	I/O	Digital I/O Power Supply
7	P3	I/O	Programmable Digital I/O or Analog Input
8	P4	I/O	Programmable Digital I/O or Analog Input
9	P5	I/O	Programmable Digital I/O or Analog Input
10	P7	I/O	Programmable Digital I/O or Analog Input
11	P8	I/O	Programmable Digital I/O or Analog Input
12	PWD	I/O	Power Down Input (Active High)
13	VBAT	PWR	Battery supply.
14	LEXT1	A	Switcher Inductor
15	VSTORE	PWR	Optional power supply, connect to VDDPA for better TX efficiency, otherwise tie to ground if not used.
16	LEXT2	A	Switcher Inductor
17	VDDIOP	PWR	1.8 V I/O power supply generated by switcher, connect to VAUX if unused.
18	AVDD1P	PWR	1 V Analog and RF core power supply generated by switcher
19	VAUX	PWR	Reserved for switching regulator internal use
20	DVDD1P	PWR	1 V Digital core power supply generated by switcher
21	DVDD1	PWR	1 V Digital core power supply
22	XTALO_32k	A	32.768 kHz crystal oscillator output
23	XTALI_32K	A	32.768 kHz crystal oscillator input

24	FLASH_CS_IN	I/O	Chip Select Input for Extended Storage (Flash), must be tied with FLASH_CS_OUT
25	FLASH_CS_OUT	I/O	Chip Select Output for Extended Storage (Flash), must be tied with FLASH_CS_IN
26	P14	I/O	Programmable Digital I/O
27	NC	NC	No connection, must be open
28	VDDIO	I/O	Digital I/O Power Supply
29	P17	I/O	Programmable Digital I/O
30	P18	I/O	Programmable Digital I/O
31	P19	I/O	Programmable Digital I/O
32	P20	I/O	Programmable Digital I/O
33	P21	I/O	Programmable Digital I/O
34	P22	I/O	Programmable Digital I/O
35	P25	I/O	Programmable Digital I/O, a weak pull low is required during MCU boot.
36	XTALI_16M	A	16 MHz crystal oscillator input
37	XTALO_16M	A	16 MHz crystal oscillator output
38	P27	I/O	Programmable Digital I/O
39	P29	I/O	Programmable Digital I/O
40	P30	I/O	Programmable Digital I/O
EPAD	VSS	GND	Ground supply for all circuits. The 40-pin QFN package has an exposed die pad (E-PAD) at its base. This E-PAD must be soldered to VSS.

### 3.4 ATM3325-5DCACM 49L WLCSP Pinout

The ATM3325 is available in a 49L WLCSP package. The pin assignment is shown in [Table 3.4-1](#). All pins are on the bottom side of the package.

Figure 3.4-1 ATM3325-5DCACM 49L WLCSP Pinout (Bottom View)

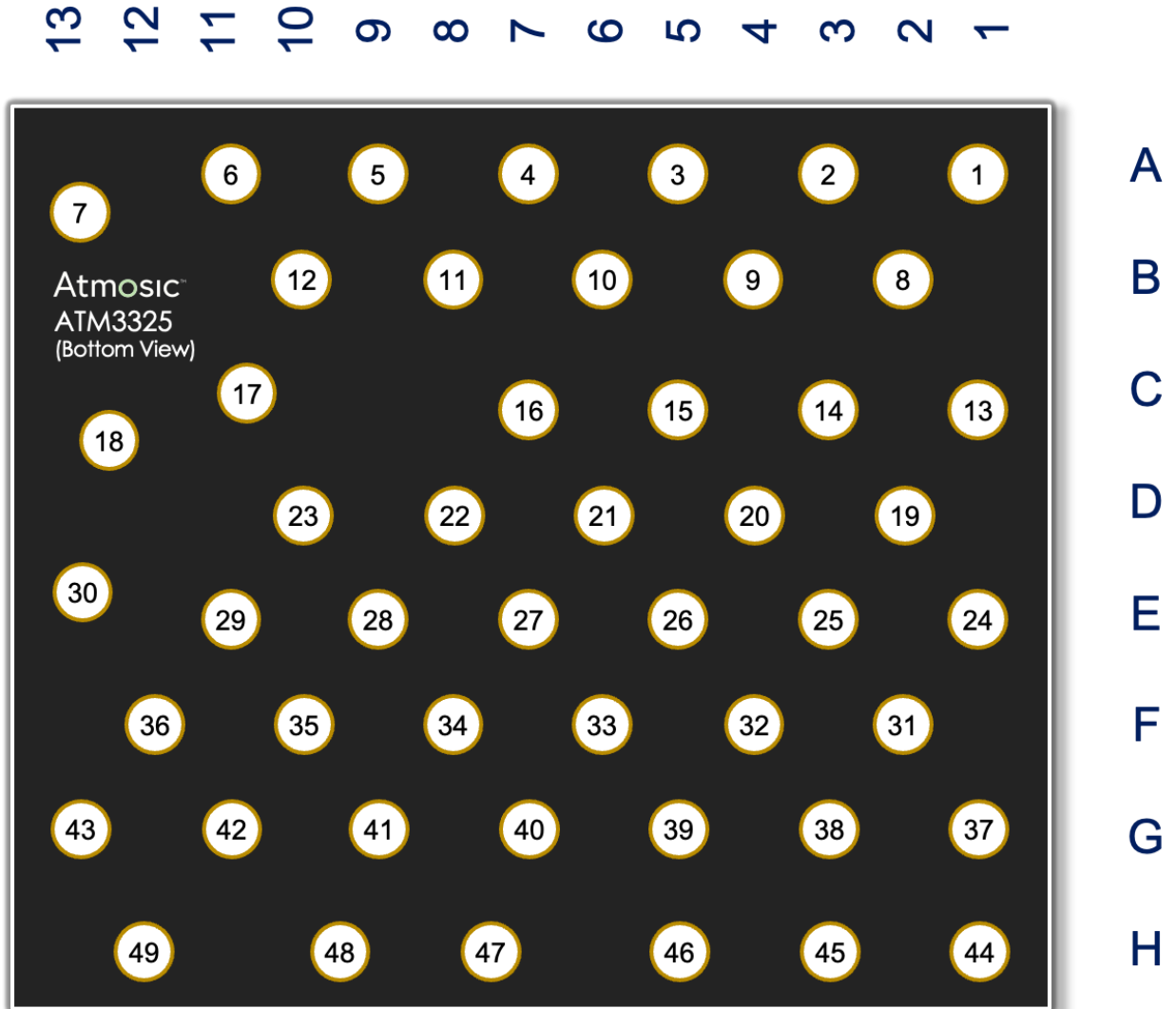

XY Coord : 0,0

**NOTE:** Pinout is preliminary, subject to change.

Pin Type Definitions	
Pin Type	Definition
I/O	Signal Input Output
RF	Radio Frequency
PWR	Power supply
A	Analog
R	Reserved
NC	No connection, must be open
GND	Ground

Table 3.4-1 ATM3325-5DCACM 49L WLCSP Pin Description

ATM3325 49L WLCSP Pin Description						
Pad Number	Grid Position	Name	Type	Description	Pin X	Pin Y
1	A1	P18	I/O	Programmable Digital I/O	2268	2410.2
2	A3	P21	I/O	Programmable Digital I/O	1917	2410.2
3	A5	P22	I/O	Programmable Digital I/O	1566	2410.2
4	A7	XTALI_16M	A	16 MHz crystal oscillator output	1215	2410.2
5	A9	XTALO_16M	A	16 MHz crystal oscillator input	864	2410.2
6	A11	P27	I/O	Programmable Digital I/O	513	2410.2
7	A13	GNDA	GND	Analog/RF ground	162	2302.2
8	B2	VDDIO	I/O	Digital I/O Power Supply	2092.5	2106
9	B4	P19	I/O	Programmable Digital I/O	1741.5	2106
10	B6	P25	I/O	Programmable Digital I/O, a weak pull low is required during MCU boot.	1390.5	2106
11	B8	P30	I/O	Programmable Digital I/O	1039.5	2106
12	B10	AVDD1	PWR	Analog core power supply	688.5	2106
13	C1	P14	I/O	Programmable Digital I/O	2268	1729.8
14	C3	P17	I/O	Programmable Digital I/O	1917	1729.8
15	C5	P20	I/O	Programmable Digital I/O	1566	1729.8
16	C7	P29	I/O	Programmable Digital I/O	1215	1729.8
17	C11	GNDA	GND	Analog/RF ground	553.5	1782
19	D2	P13	I/O	Programmable Digital I/O	2092.5	1425.6
20	D4	P15	I/O	Programmable Digital I/O	1741.5	1425.6
21	D6	GND	GND	SoC ground	1339.5	1425.6

22	D8	GND	GND	SoC ground	1039.5	1425.6
23	D10	VDDPA	PWR	PA power supply	688.5	1425.6
18	C13	RFIO	RF	2.4 GHz Single-ended RF I/O for Bluetooth radio	229.5	1638
24	E1	XTALI_32k	A	32.768 kHz crystal oscillator input	2268	1121.4
25	E3	P12	I/O	Programmable Digital I/O	1917	1121.4
26	E5	GND	GND	SoC ground	1566	1121.4
27	E7	GND	GND	SoC ground	1215	1121.4
28	E9	GND	GND	SoC ground	864	1121.4
29	E11	P0	I/O	Programmable Digital I/O	513	1121.4
30	E13	P1	I/O	Programmable Digital I/O	171	1202.4
31	F2	XTALO_32k	A	32.768 kHz crystal oscillator output	2092.5	817.2
32	F4	GND	GND	SoC ground	1741.5	817.2
33	F6	GNDP	GND	PMU ground	1039.5	817.2
34	F8	GND	GND	SoC ground	1039.5	817.2
35	F10	P5	I/O	Programmable Digital or Analog Input	688.5	817.2
36	F12	P4	I/O	Programmable Digital or Analog Input	337.5	817.2
37	G1	DVDD1	PWR	1 V Digital core power supply	2268	513
38	G3	VAUX	PWR	Reserved for switching regulator internal use	1917	513
39	G5	VDDIOP	PWR	1.8 V I/O power supply generated by switcher, connect to VAUX if unused.	1566	513
40	G7	GNDP	GND	PMU Ground	1215	513
41	G9	P7	I/O	Programmable Digital I/O or Analog Input	864	513
42	G11	P6	I/O	Programmable Digital I/O or Analog Input	513	513
43	G13	P3	I/O	Programmable Digital I/O or Analog Input	162	513
44	H1	VBATLI	PWR	2.7 V to 4.2 V lithium ion battery supply in place of VBAT. If lithium ion battery is not used, this pin is recommended to be connected to VBAT.	2268	162
45	H3	AVDD1P	PWR	1 V Analog and RF core power supply generated by switcher	1917	162
46	H5	LEXT2	A	Switcher Inductor	1566	162
47	H7	LEXT1	A	Switcher Inductor	1125	162
48	H9	VBAT	PWR	Battery supply. Must connect to 10 $\mu$ F capacitor if VBATLI is used.	774	162
49	H12	PWD	I/O	Power Down Input (Active High)	315	162

## 4 Mechanical Drawing

### 4.1 ATM3330-5DCAQN 7x7 mm, 56-pin QFN Package

Figure 4.1-1 ATM3330-5DCAQN 7x7 mm, 56-Pin QFN Mechanical Drawing

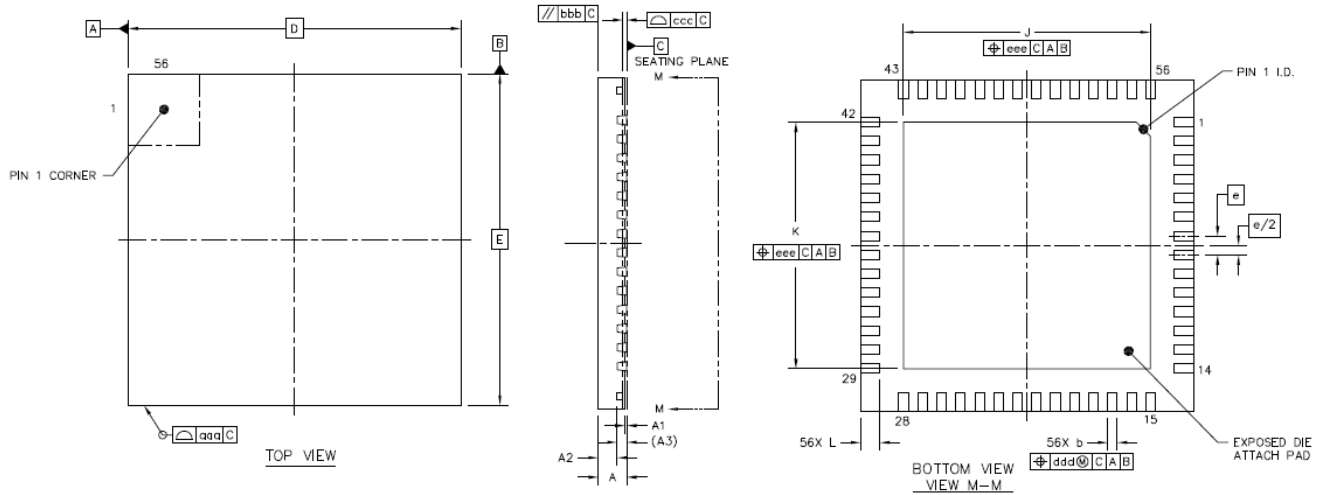

Table 4.1-1 ATM3330-5DCAQN 7x7 mm, 56-Pin QFN Dimensions

		Symbol	Min	Nom	Max
Total Thickness		A	0.55	0.60	0.65
Stand Off		A1	0	---	0.05
Mold Thickness		A2	0.35	0.40	0.45
L/F Thickness		A3	0.203 REF		
Lead Width		b	0.15	0.2	0.25
Body Size	X	D	7 BSC		
	Y	E	7 BSC		
Lead Pitch		e	0.4 BSC		
EP Size	X	J	5.1	5.2	5.3
	Y	K	5.1	5.2	5.3
Lead Length		L	0.35	0.4	0.45
Package Edge Tolerance		aaa	0.1		
Mold Flatness		bbb	0.1		
Coplanarity		ccc	0.08		
Lead Offset		ddd	0.1		
Exposed Pad Offset		eee	0.1		

Notes:

1. All dimensions are in millimeters.
2. Coplanarity applies to leads, corner leads and die attached pad.

Figure 4.1-2 ATM3330-5DCAQN 7x7 mm, 56-Pin QFN Land Pattern

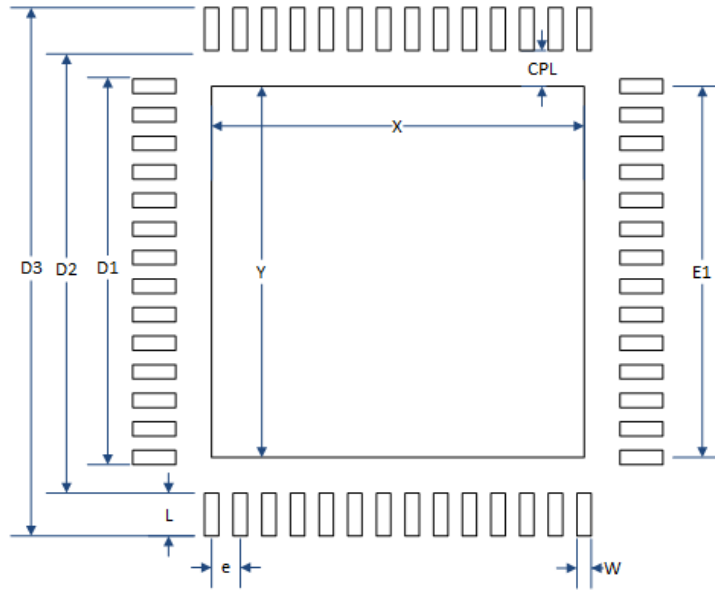

Table 4.1-2 ATM3330-5DCAQN 7x7 mm, 56-Pin QFN Land Pattern Dimensions

Symbol	Typ
CPL	0.50
D1	5.45
D2	6.2
D3	7.0
e	0.4
E1	5.2
L	0.6
W	0.2
X	5.2
Y	5.2

Notes:

1. All dimensions are in millimeters (mm) unless otherwise noted.
2. The land pattern is based on the IPC-7351 guidelines. There may be other options specified in that publication.
3. The recommended reflow profile is per the IPC/JEDEC J-STD-020 specification.
4. The notes above and land pattern are recommendations only. Customers may need to use different parameters as required for their application, materials, SMT process, and tooling requirements.



## 4.2 ATM3325-5DCAQK 5x5 mm, 40-pin QFN Package

Figure 4.2-1 ATM3325-5DCAQK 5x5 mm, 40-Pin QFN Mechanical Drawing

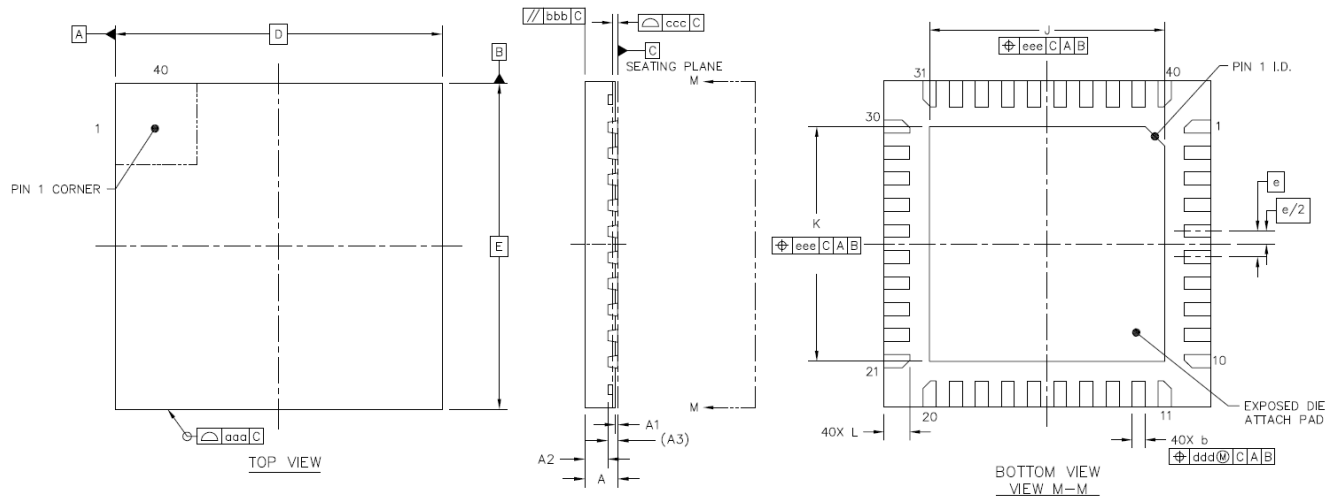

Table 4.2-1 ATM3325-5DCAQK 5x5 mm, 40-Pin QFN Dimensions

		Symbol	Min	Nom	Max
Total Thickness		A	0.5	0.55	0.6
Stand Off		A1	0	0.035	0.05
Mold Thickness		A2	---	0.4	---
L/F Thickness		A3	0.152 REF		
Lead Width		b	0.15	0.2	0.25
Body Size	X	D	5 BSC		
	Y	E	5 BSC		
Lead Pitch		e	0.4 BSC		
EP Size	X	J	3.5	3.6	3.7
	Y	K	3.5	3.6	3.7
Lead Length		L	0.35	0.4	0.45
Package Edge Tolerance		aaa	0.1		
Mold Flatness		bbb	0.1		
Coplanarity		ccc	0.08		
Lead Offset		ddd	0.1		
Exposed Pad Offset		eee	0.1		

Notes:

1. All dimensions are in millimeters.
2. Coplanarity applies to leads, corner leads and die attached pad.

Figure 4.2-2 ATM3325-5DCAQK 5x5 mm, 40-Pin QFN Land Pattern

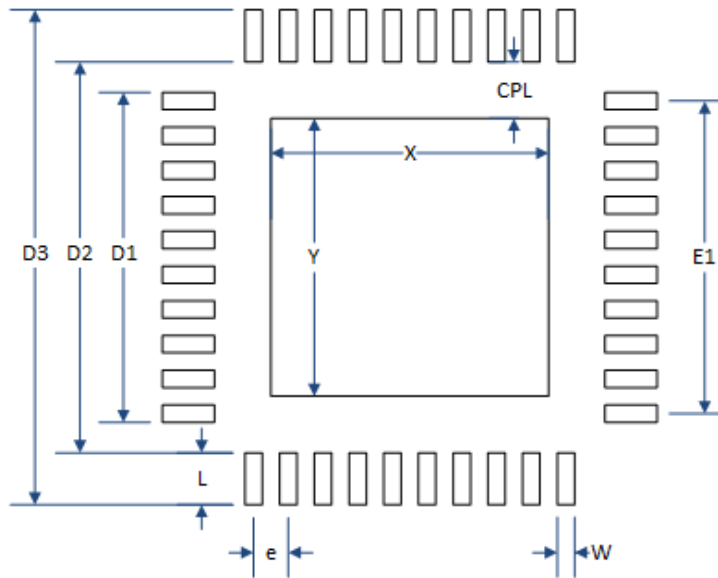

Table 4.2-2 ATM3325-5DCAQK 5x5 mm, 40-Pin QFN Land Pattern Dimensions

Symbol	Typ
CPL	0.65
D1	3.8
D2	4.5
D3	5.7
e	0.4
E1	3.6
L	0.6
W	0.2
X	3.2
Y	3.2

Notes:

1. All dimensions are in millimeters (mm) unless otherwise noted.
2. The land pattern is based on the IPC-7351 guidelines. There may be other options specified in that publication.
3. The recommended reflow profile is per the IPC/JEDEC J-STD-020 specification.
4. The notes above and land pattern are recommendations only. Customers may need to use different parameters as required for their application, materials, SMT process, and tooling requirements.

### 4.3 ATM3325-5LCAQK 5x5 mm, 40-pin QFN with Extended Storage Package

Figure 4.3-1 ATM3325-5LCAQK 5x5 mm, 40-Pin QFN with Extended Storage Mechanical Drawing

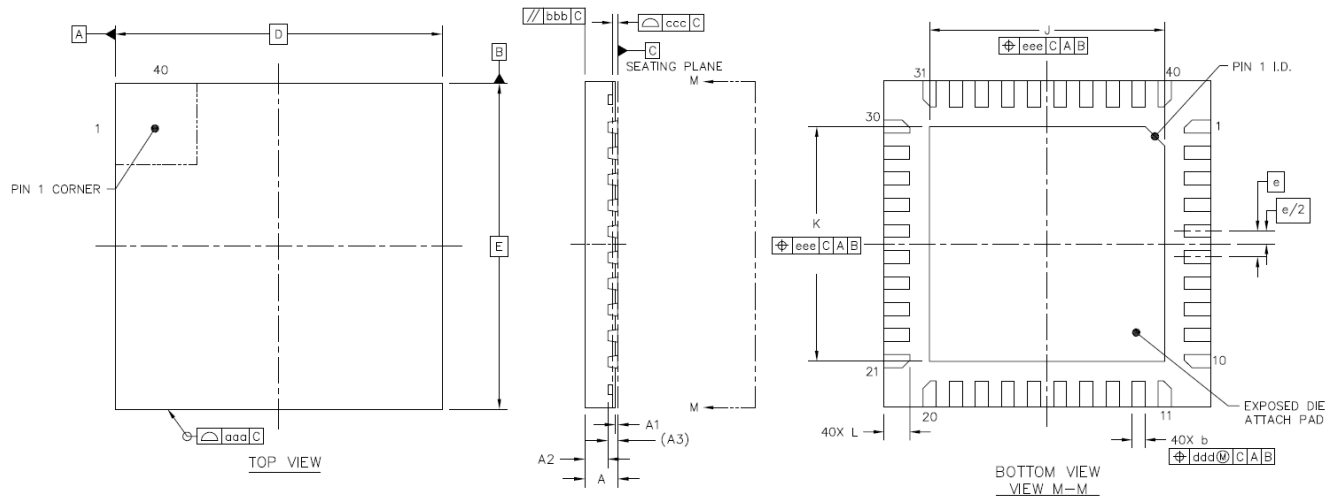

Table 4.3-1 ATM3325-5LCAQK 5x5 mm, 40-Pin QFN with Extended Storage Dimensions

		Symbol	Min	Nom	Max
Total Thickness		A	0.75	0.85	0.9
Stand Off		A1	0	---	0.05
Mold Thickness		A2	0.6	0.65	0.7
L/F Thickness		A3	0.152 REF		
Lead Width		b	0.15	0.2	0.25
Body Size	X	D	4.9	5	5.1
	Y	E	4.9	5	5.1
Lead Pitch		e	0.4 BSC		
EP Size	X	J	3.5	3.6	3.7
	Y	K	3.5	3.6	3.7
Lead Length		L	0.35	0.4 <sup>3</sup>	0.45
Package Edge Tolerance		aaa	0.1		
Mold Flatness		bbb	0.1		
Coplanarity		ccc	0.08		
Lead Offset		ddd	0.1		
Exposed Pad Offset		eee	0.1		

Notes:

1. All dimensions are in millimeters.
2. Coplanarity applies to leads, corner leads and die attached pad.
3. Lead length for chamfered leads are 0.4mm on long side and 0.3mm on the short side

Figure 4.3-2 ATM3325-5LCAQK 5x5 mm, 40-Pin QFN with Extended Storage Land Pattern

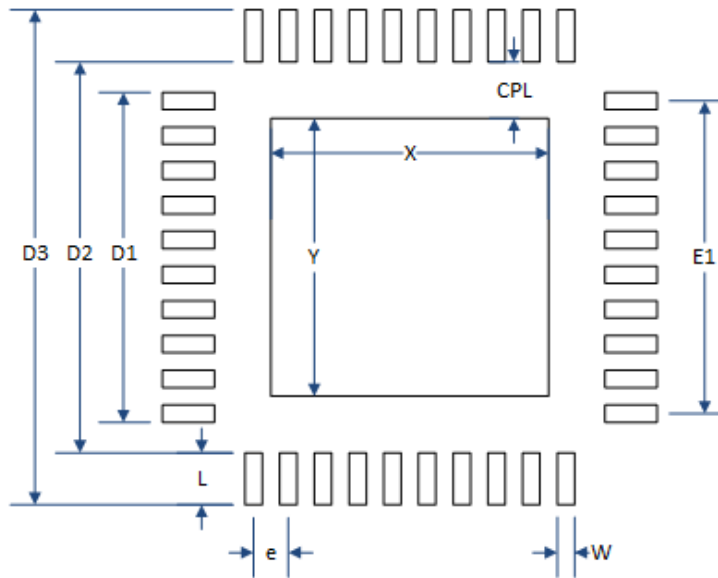

Table 4.3-2 ATM3325-5LCAQK 5x5 mm, 40-Pin QFN with Extended Storage Land Pattern Dimensions

Symbol	Typ
CPL	0.65
D1	3.8
D2	4.5
D3	5.7
e	0.4
E1	3.6
L	0.6
W	0.2
X	3.2
Y	3.2

Notes:

1. All dimensions are in millimeters (mm) unless otherwise noted.
2. The land pattern is based on the IPC-7351 guidelines. There may be other options specified in that publication.
3. The recommended reflow profile is per the IPC/JEDEC J-STD-020 specification.
4. The notes above and land pattern are recommendations only. Customers may need to use different parameters as required for their application, materials, SMT process, and tooling requirements.

### 4.4 ATM3325-5DCACM 49L WLCSP Package

Figure 4.4-1 ATM3325-5DCACM 49L WLCSP Mechanical Drawing

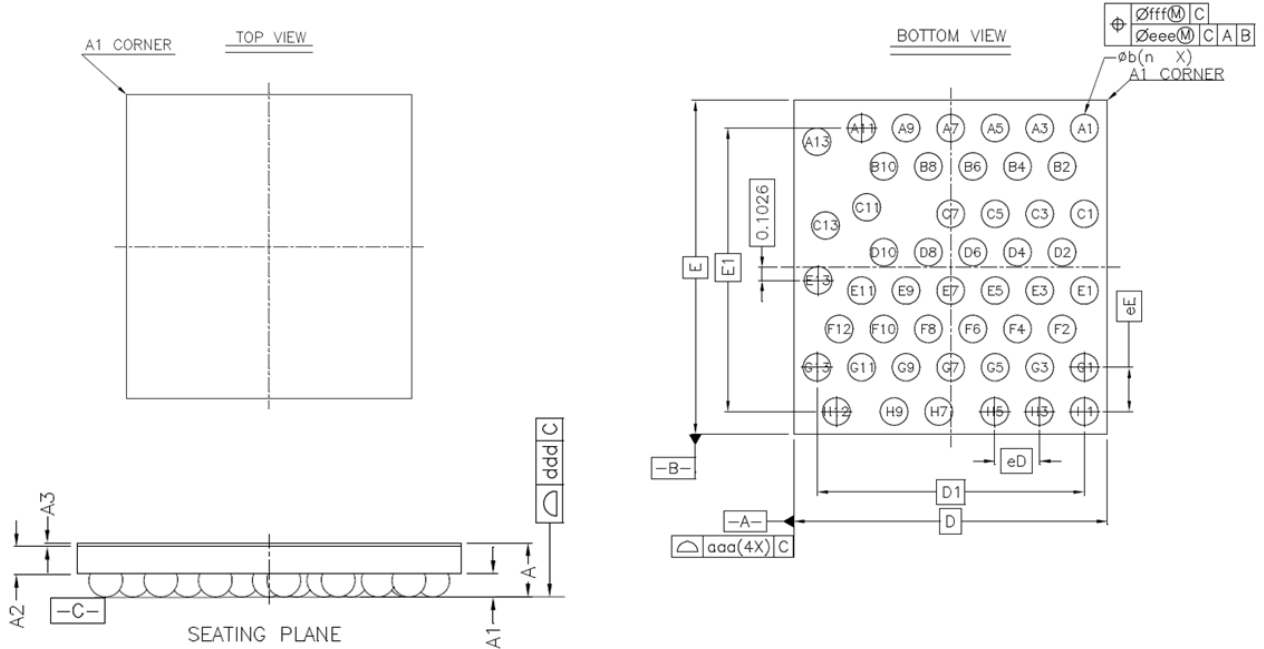

Table 4.4-1 ATM3325-5DCACM 49L WLCSP Dimensions

	Symbol	Min	Nom	Max
Total Thickness	A	0.313	0.352	0.391
Stand Off	A1	0.122	0.152	0.182
Wafer Thickness	A2	0.175 +/- 0.025		
Backside Coating Thickness	A3	0.025		
Body Size	D	2.4706 BSC		
	E	2.6506 BSC		
Ball Diameter (Size)		0.200		
Ball/Bump Width	b	0.188	0.218	0.248
Ball/Bump Pitch	eD	0.351		
	eE	0.351		
Ball/Bump Count	n	49		
Edge Ball Center to Center	D1	2.1060 BSC		
	E1	2.2482BSC		
Package Edge Tolerance	aaa	0.025		
Coplanarity (whole wafer)	ddd	0.075		
Ball/Bump Offset (package)	eee	0.050		
Ball/Bump Offset (Ball)	fff	0.015		

## 5 Part Ordering

**Table 5-1 Part Ordering Numbers**

Part Number	Product Line	Description
ATM3330-5DCAQN-TR	ATM33 Bluetooth LE Wireless MCU	7x7 mm QFN 56 pin, no energy-harvesting, standard Reel, 13” 2.5K devices/reel
ATM3330-5DCAQN	ATM33 Bluetooth LE Wireless MCU	7x7 mm QFN 56 pin, no energy-harvesting, sampling quantity in tray, not for production volume
ATM3325-5DCAQK-SR	ATM33 Bluetooth LE Wireless MCU	5x5 mm QFN 40 pin, no energy-harvesting, no Wakeup Receiver, small Reel, 7” 1K devices/reel
ATM3325-5DCAQK	ATM33 Bluetooth LE Wireless MCU	5x5 mm QFN 40 pin, no energy-harvesting, no Wakeup Receiver, sampling quantity in tray, not for production volume
ATM3325-5LCAQK-SR	ATM33 Bluetooth LE Wireless MCU	5x5 mm QFN 40 pin with 1 MB extended storage, no energy-harvesting, no Wakeup Receiver, small Reel, 7”, 1K devices/reel
ATM3325-5LCAQK	ATM33 Bluetooth LE Wireless MCU	5x5 mm QFN 40 pin with 1MB extended storage, no energy-harvesting, no Wakeup Receiver, sampling quantity in tray, not for production volume
ATM3325-5DCACM-SR	ATM33 Bluetooth LE Wireless MCU	49L WLCSP, no energy-harvesting, no Wakeup Receiver, small Reel, 7” 2K devices/reel
ATM3325-5DCACM	ATM33 Bluetooth LE Wireless MCU	49L WLCSP, no energy-harvesting, no Wakeup Receiver, sampling quantity in tray, not for production volume

## Reference Documents

Document Title	Description	Link
Arm® TrustZone Technology for the Armv8-M Architecture v2.1	TrustZone Architecture Manual	<a href="https://developer.arm.com/documentation">https://developer.arm.com/documentation</a>
Arm® Cortex®-M33 Devices Generic User Guide Revision r1p0	Cortex M33 Users Guide	<a href="https://developer.arm.com/documentation">https://developer.arm.com/documentation</a>
ARM®v8-M Architecture Reference Manual ARM DDI 0553A.e	ARMv8-M Core architecture reference.	<a href="https://developer.arm.com/documentation">https://developer.arm.com/documentation</a>

## Revision History

Date	Version	Description
September 11, 2024	0.89	Update <a href="#">Table 2-1</a>
August 6, 2024	0.88	Update <a href="#">Table 5-1 Part Ordering Numbers</a> for ATM3325-5DCACM-SR, to 2K devices/reel
June, 2024	0.87	Added <a href="#">Table 2-10 SoC Power Consumption</a>
December 6, 2023	0.86	Updated <a href="#">Table 2-2 Recommended Operating Conditions</a>
November 2, 2023	0.85	Updated <a href="#">Table 2-1 Maximum Electrical Ratings</a>
August 30, 2023	0.84	Updated <a href="#">Table 2-2 Recommended Operating Conditions</a> .
August 23, 2023	0.83	Format change, no content change.
July 28, 2023	0.82	Updated <a href="#">Table 2-1 Maximum Electrical Ratings</a> , <a href="#">Table 2-2 Recommended Operating Conditions</a> , <a href="#">Table 2-3 Radio Transceiver Characteristics</a> , <a href="#">Table 2-5 PMU Characteristics</a> , <a href="#">Table 2-6 GPIO Characteristics</a> , <a href="#">Table 2-8 Radio Power Consumption</a> .
July 19, 2023	0.81	Updated <a href="#">Clocks</a> section, bullet PDM and I2S, MHz to kHz, <a href="#">Table 2-2 Recommended Operating Conditions</a> , <a href="#">Table 2-6 GPIO Characteristics</a> , <a href="#">ATM3325-5LCAQK 5x5 mm, 40-pin QFN with Extended Storage Package</a> section, <a href="#">Table 4.3-1 ATM3325-5LCAQK 5x5 mm, 40-Pin QFN with Extended Storage Dimensions</a> , <a href="#">Table 4.4-1 ATM3325 49L WLCSP Dimensions</a> .
June 5, 2023	0.80	Added <a href="#">Figure 4.1-2 ATM3330 7x7 mm, 56-Pin QFN Land Pattern</a> , <a href="#">Table 4.1-2 ATM3330 7x7 mm, 54-Pin QFN Land Pattern Dimensions</a> , <a href="#">Figure 4.2-2 ATM3325 5x5 mm, 40-Pin QFN Land Pattern</a> , <a href="#">Table 4.2-2 ATM3325 5x5 mm, 40-Pin QFN Land Pattern Dimensions</a> , <a href="#">Figure 4.3-2 ATM3325 5x5 mm, 40-Pin QFN Land Pattern</a> , <a href="#">Table 4.3-2 ATM3325 5x5 mm, 40-Pin QFN Land Pattern Dimensions</a> ,
May 31, 2023	0.79	Updated <a href="#">Peripherals and I/O</a> , I2C bullet, <a href="#">Table 2-1 Maximum Electrical Ratings</a> , <a href="#">Table 2-2 Recommended Operating Conditions</a> , <a href="#">Table 2-5 PMU Characteristics</a> , <a href="#">Table 2-6 GPIO Characteristics</a> , <a href="#">Table 2-9 SoC Power Consumption</a> , <a href="#">Figure 3.1-1 ATM3330 7x7 mm, 56-Pin QFN Pinout (Top View)</a> , <a href="#">Table 3.1-1 ATM3330 7x7 mm, 56-Pin QFN Pin Description</a> , changed pin 17 and 18 to RES.
April 25, 2023	0.78	Updated <a href="#">Overview</a> , <a href="#">Features</a> , <a href="#">Table 2-9 SoC Power Consumption</a> ,
April 3, 2023	0.77	Updated <a href="#">Table 2-7 Application ADC Characteristics</a> .
April 3, 2023	0.76	Updated <a href="#">Features</a> , <a href="#">Power Modes</a> , <a href="#">Modem. Wakeup Receiver</a> , <a href="#">PMU</a>



Date	Version	Description
		<a href="#">Configurations</a> , <a href="#">OTP Access</a> , <a href="#">Table 2-1 Maximum Electrical Ratings</a> , <a href="#">Table 2-2 Recommended Operating Conditions</a> , <a href="#">Table 2-3 Radio Transceiver Characteristics</a> , <a href="#">Table 2-6 GPIO Characteristics</a> , <a href="#">MCU &amp; Memory</a> , <a href="#">Table 2-7 Application ADC Characteristics</a> , <a href="#">Table 2-8 Radio Power Consumption</a> , <a href="#">Table 2-9 SoC Power Consumption</a> , <a href="#">Table 2-11 Flash (Extended Storage) Characteristics</a> .
March 27, 2023	0.75	Added <a href="#">Table 2-11 Flash (Extended Storage) Characteristics</a> .
February 13, 2023	0.74	Updated <a href="#">Table 3.1-1 ATM3330 7x7 mm, 56-Pin QFN Pin Description</a> . <a href="#">Table 4.2-1 ATM3325 5x5 mm, 40-Pin QFN Dimensions</a> , <a href="#">Figure 4.4-1 ATM3325 49L WLCSP Mechanical Drawing</a> , <a href="#">Table 4.4-1 ATM3325 49L WLCSP Dimensions</a> . Added <a href="#">Figure 4.3-1 ATM3325 5x5 mm, 40-Pin QFN with Extended Storage Mechanical Drawing</a> , <a href="#">Table 4.3-1 ATM3325 5x5 mm, 40-Pin QFN with Extended Storage Dimensions</a> .
January 24, 2023	0.73	Updated <a href="#">Overview</a> , <a href="#">Features</a> , <a href="#">MCU &amp; Memory</a> , <a href="#">Interrupts</a> , <a href="#">Peripherals and I/O</a> , <a href="#">Pin Multiplexing</a> , <a href="#">Part Ordering</a> sections to include 1 MB extended flash storage (selected package). Updated <a href="#">Table 4.1-1 ATM3330 7x7 mm, 56-Pin QFN Dimensions</a> . Add <a href="#">ATM3325 5x5 mm with Extended Storage, 40-pin QFN Pinout</a> .
January 13, 2023	0.72	Updated <a href="#">Peripherals and I/O</a> , <a href="#">Table 1.1-1 System Memory Map</a> , <a href="#">Table 2-1 Maximum Electrical Ratings</a> , <a href="#">Table 2-2 Recommended Operating Conditions</a> , <a href="#">Table 2-9 SoC Power Consumption</a> , <a href="#">Table 3.1-1 ATM3330 7x7 mm, 56-pin QFN Pin Description</a> , <a href="#">Table 3.2-1 ATM3325 5x5 mm, 40-pin QFN Pin Description</a> , <a href="#">Table 3.3-1 ATM3325 49L WLCSP Pin Description</a> .
December 6, 2022	0.71	Updated <a href="#">Table 1.4-1 PMU External Pins</a> , <a href="#">PMU Configurations</a> section, <a href="#">Table 2-3 Radio Transceiver Characteristics</a> .
November 21, 2022	0.70	Updated <a href="#">Features</a> , I2S and Application ADC under <a href="#">Peripherals and I/O</a> . Renamed VDD1A to AVDD1, and updated <a href="#">Power Management Unit (PMU)</a> , <a href="#">Figure 3.1-1 ATM3330 7x7 mm, 56-Pin QFN Pinout (Top View)</a> , <a href="#">Table 3.1-1 ATM3330 7x7 mm, 56-Pin QFN Pin Description</a> , <a href="#">Figure 3.2-1 ATM3325 5x5 mm, QFN Pinout (Top View)</a> , <a href="#">Figure 3.2-1 ATM3325 5x5 mm, 40-Pin QFN Pinout (Top View)</a> <a href="#">Figure 3.3-1 ATM3325 49L WLCSP Pinout (Bottom View)</a> . <a href="#">Table 3.3-1 ATM3325 49L WLCSP Pin Description</a> . Updated <a href="#">Table 2-1 Maximum Electrical Ratings</a> , <a href="#">Table 2-2 Recommended Operating Conditions</a> , <a href="#">Table 2-4 Wakeup Receiver Characteristics</a> , <a href="#">Table 2-9 SoC Power Consumption</a> .
September 20, 2022	0.67	Updated <a href="#">Features</a> section, <a href="#">Table 2-1 Maximum Electrical Ratings</a> , <a href="#">Table 2-3 Radio Transceiver Characteristics</a> , <a href="#">Table 2-7 Application ADC Characteristics</a> , <a href="#">Table 2-9 SoC Power Consumption</a> .
September 3, 2022	0.66	Updated <a href="#">Features</a> , <a href="#">Peripherals and I/O</a> sections, <a href="#">Table 1.1.1 Clocks</a> , <a href="#">Table 2-10 RRAM Characteristics</a> .

Date	Version	Description
August 16, 2022	0.65	Updated <a href="#">Table 2-1 Maximum Electrical Ratings</a> , <a href="#">Table 2-2 Recommended Operating Conditions</a> , <a href="#">Table 2-3 Radio Transceiver Characteristics</a> , <a href="#">Table 2-5 PMU Characteristics</a> , <a href="#">Table 2-6 GPIO Characteristics</a> , <a href="#">Table 2-7 Application ADC Characteristics</a> , <a href="#">Table 2-9 SoC Power Consumption</a> , <a href="#">Part Ordering</a> section; corrected typos VBALTLI should be VBATLI.
June 14, 2022	0.64	Updated <a href="#">Quad SPI</a> , <a href="#">FLASH</a> , <a href="#">Table 2-10 RRAM Characteristics</a> .
June 8, 2022	0.63	Updated <a href="#">Table 5-1 Part Ordering Numbers</a> .
June 1, 2022	0.62	Updated <a href="#">Clocks</a> , Backplane clock bullet, updated pin 22 in <a href="#">Figure 3.1-1 ATM3330 7x7 mm, 56-pin QFN Pinout (Top View)</a> , and <a href="#">Table 3.1-1 ATM3330 7x7 mm, 56-Pin QFN Pin Description</a> .
May 13, 2022	0.61	Updated <a href="#">Features</a> , <a href="#">GPIO Characteristics</a> , <a href="#">Application ADC Characteristics</a> , <a href="#">SoC Power Consumption</a> . Added <a href="#">RRAM Characteristics</a> .
April 8, 2022	0.60	Removed support of ATM3330 5x5 mm QFN package. Added support of ATM3325 5x5 mm QFN and 49L WLCSP packages throughout the document.
March 4, 2022	0.57	Corrected typos.
February 22, 2022	0.56	Updated <a href="#">SoC Power Consumption</a> .
February 15, 2022	0.55	Updated <a href="#">Overview</a> section.
February 15, 2022	0.54	Updated <a href="#">Overview</a> , <a href="#">Part Ordering</a> sections.
January 31, 2022	0.53	Added wakeup receiver information <a href="#">Wakeup Receiver</a> and in <a href="#">Pinout Description</a> , added <a href="#">Wakeup Receiver Characteristics</a> and <a href="#">Radio Power Consumption</a> tables, corrected typos.
December 3, 2021	0.52	Changed part number, updated <a href="#">Overview</a> , <a href="#">Pin Description</a> , <a href="#">Part Ordering</a> sections, corrected typos.
November 9, 2021	0.51	Changed format. Updated <a href="#">MCU &amp; Memory</a> , <a href="#">Security</a> , <a href="#">Sensor Hub</a> , <a href="#">Timers and Interrupts</a> , <a href="#">Peripherals and I/O</a> , <a href="#">Electrical Specification</a> , <a href="#">Pin Description</a> , <a href="#">Part Ordering</a> sections.
August 20, 2021	0.50	Initial version created.



[www.Atmosic.com](http://www.Atmosic.com)

#### ATMOSIC TECHNOLOGIES - DISCLAIMER

This product datasheet is intended to be a general informational aid and not a substitute for any literature or labeling accompanying your purchase of the Atmosic product. Atmosic reserves the right to amend its product literature at any time without notice and for any reason, including to improve product design or function. While Atmosic strives to make its datasheets accurate and current, Atmosic makes no warranty or representation that the information contained in this datasheet is completely accurate, and Atmosic hereby disclaims (i) any and all liability for any errors or inaccuracies contained in any datasheet or in any other product literature and any damages or lost profits resulting therefrom; (ii) any and all liability and responsibility for any action you take or fail to take based on the information contained in this datasheet; and (iii) any and all implied warranties which may attach to this datasheet, including warranties of fitness for particular purpose, non-infringement and merchantability. Consequently, you assume all risk in your use of this datasheet, the Atmosic product, and in any action you take or fail to take based upon the information in this datasheet. Any statements in this datasheet in regard to the suitability of an Atmosic product for certain types of applications are based on Atmosic's general knowledge of typical requirements in generic applications and are not binding statements about the suitability of Atmosic products for any particular application. It is your responsibility as the customer to validate that a particular Atmosic product is suitable for use in a particular application. All content in this datasheet is proprietary, copyrighted, and owned or licensed by Atmosic, and any unauthorized use of content or trademarks contained herein is strictly prohibited.

Copyright ©2021-2023 by Atmosic Technologies. All rights reserved. Atmosic logo is a registered trademark of Atmosic Technologies Inc. All other trademarks are the properties of their respective holders. This preliminary datasheet is subject to change without notice.