

ATM2251 (CSP) Bring-up Module

Release Date	Revision	Design Eng.	Design Note
02/17/2021	A1	SK	Intial Release
12/03/2021	A1-02	AD	Changed C13 (VDDAUX) from 1uF to 10uF to support fast power cycling

Atmosic Technologies, Inc
2105 South Bascom Avenue, Suite 220
Campbell, CA 95008

ATMOSIC TECHNOLOGIES INC		
Title ATM2251 (CSP) Bring-up Module		
Size B	Document Number 033-01-000-	Rev A1-02
Date:	Friday, December 03, 2021	Sheet 1 of 2

Atmosic Technologies Proprietary and Confidential

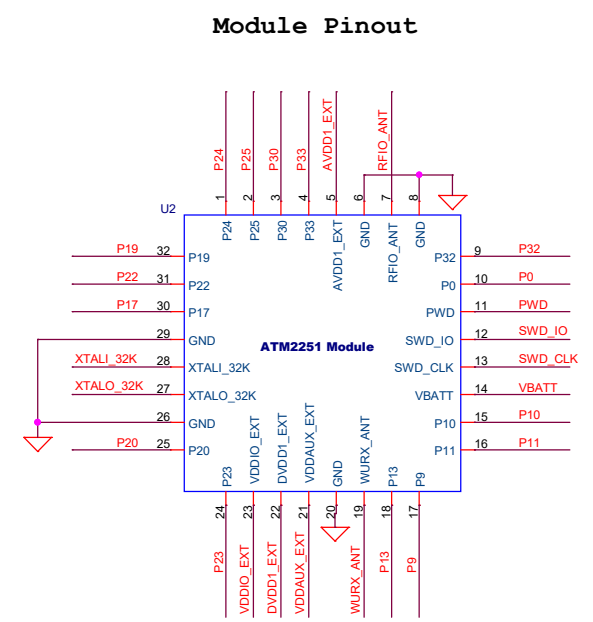
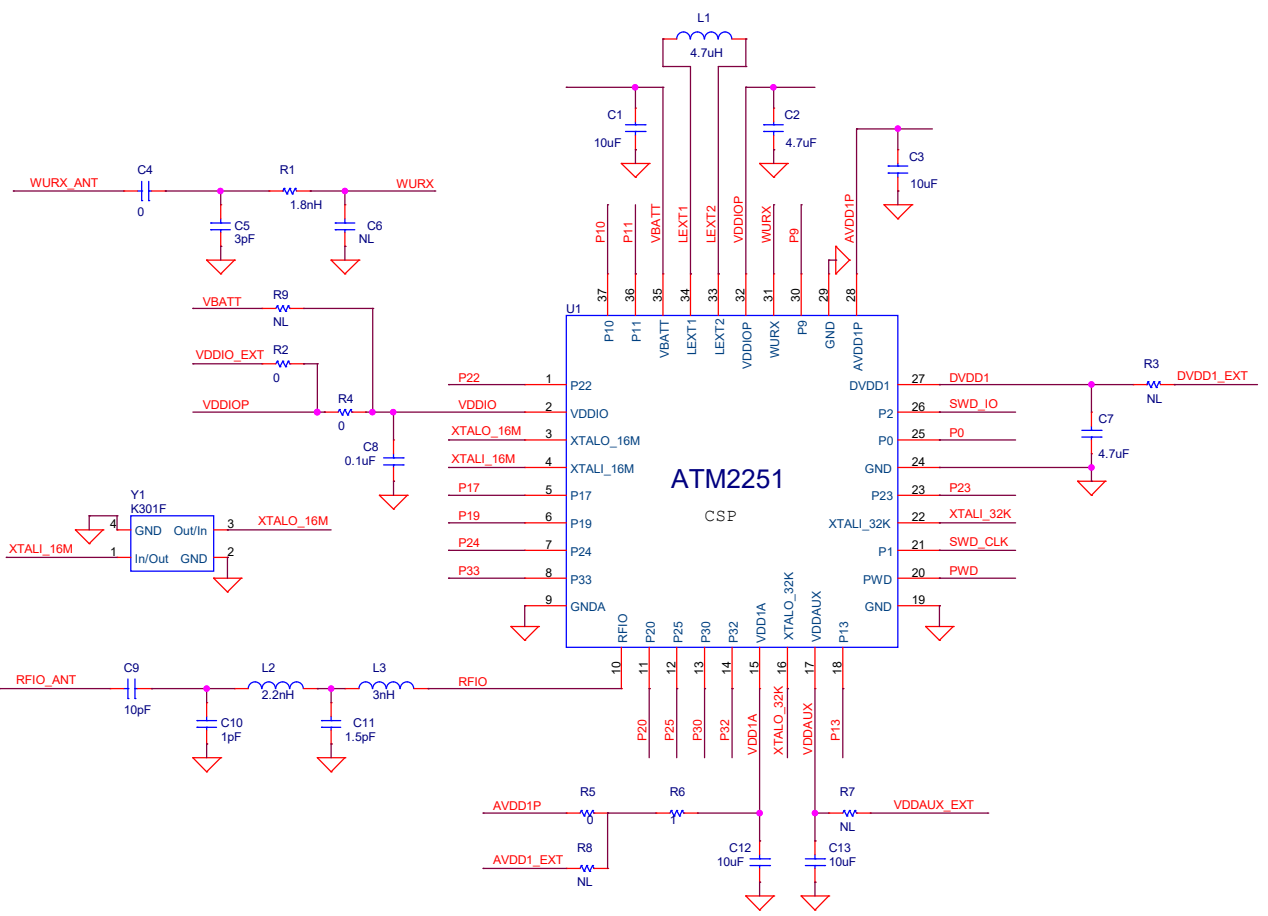

IO config	R4	R7	R9	
Internal IO	0	NL	NL	
External IO	NL	0	0	JP8 stuffed on CB

ATMOSIC TECHNOLOGIES INC

Title: **ATM2251 (CSP) Bring-up Module**

Size B | Document Number: 033-01-000 | Rev A1-02

Date: Friday, December 03, 2021 | Sheet 2 of 2