

# Atmosic RF Test Tool

## User Guide

**SUMMARY:** The document provides instructions on how to install and operate the Atmosic RF Test Tool to test Tx and Rx RF performance of the ATM2/ATM3, ATM33/e, ATM34/e or ATM5/e Wireless SoC Series. The RF Test Tool can also be used for FCC/CE pretest and certification, including BTCS (Bluetooth Channel Sounding) Tests.



**Atmosic™**

Atmosic RF Test Tool User Guide

April 27, 2026

Doc. No. ATM-UGRF-0067

# Table of Contents

<b>Table of Contents</b>	<b>2</b>
<b>List of Figures</b>	<b>3</b>
<b>List of Tables</b>	<b>3</b>
<b>1. Overview</b>	<b>5</b>
<b>2. Hardware and Software Requirements</b>	<b>5</b>
2.1 Supported EVK	5
2.2 Supported OS	6
<b>3. Environment Setup</b>	<b>7</b>
3.1 Hardware Setup	7
3.1.1 Antenna Configurations on ATM5/e EVB	9
3.2 Setup Software	9
3.2.1 Install WinUSB Driver Using Zadig	10
3.2.2 Program Firmware	11
3.2.3 Launch RF Test Tool	12
3.3 UART Ports	13
3.4 Running the RF Test Tool	16
<b>4. RF Test Functions</b>	<b>18</b>
4.1 Tx Test	20
4.1.1 Burst Tx Mode	22
4.1.2 Infinite Tx Mode	22
4.1.3 Single-Tone Transmission	23
4.2 Rx Test	23
4.2.1 Rx Mode	23
<b>5. Check the DUT RF Function Using the RF Test Tool</b>	<b>23</b>
<b>6. 16 MHz Crystal Calibration Using RF Test Tool</b>	<b>25</b>
<b>7. ATM33/ATM34 32 kHz Crystal Calibration</b>	<b>27</b>
<b>8. Change UART0 Pins</b>	<b>28</b>
8.1 Change UART0 Pins for Atmosic Bare Metal SDK	28
8.2 Change UART0 Pins for Zephyr	28
<b>9. ATM34 Bluetooth Channel Sounding FCC/CE Test</b>	<b>29</b>
<b>References</b>	<b>31</b>
<b>Revision History</b>	<b>32</b>

## List of Figures

Figure 3-1 - RF Test Tool Hardware Environment for the ATM2/ATM33 with Atmosic Interface Board

Figure 3-2 - RF Test Tool Hardware Environment for the ATM33/e or ATM34/e EVB

Figure 3-3 - RF Test Tool Hardware Environment for the ATM5/e EVB

Figure 3-4 - Replace Driver Using Zadig

Figure 3-5 - Replace Driver for ATM2/ATM3 Using Zadig

Figure 3-6 - Console to select the platform

Figure 3-7 - Console to select the EVB

Figure 3-8 - runui.bat File in RF Test Tool Folder

Figure 3-9 - New COM Ports from the Interface Board of ATM2/ATM3 EVK

Figure 3-10 - New COM Ports from the ATM33/e and ATM34/e EVK

Figure 3-11 - New COM Ports from the ATM5/e EVK

Figure 3-12 - RF Test Tool Interface Setting

Figure 3-13 - The successful message of resetting the EVB

Figure 4-1 - RF Test Tool User Interface and Test Items

Figure 4-2 - ATM2/ATM3 EVK Tx Test Environment Setting

Figure 4-3 - ATM33/e or ATM34/e EVK Tx Test Environment Setting

Figure 4-4 - ATM5/e EVK Tx Test Environment Setting

Figure 5-1 - Test Environment to Check DUT RF Function Using RF Test Tool for the ATM2/ATM3

Figure 5-2 - Test Environment to Check DUT RF Function Using RF Test Tool for the ATM33/e or ATM34/e

Figure 5-3 - Test Environment to Check DUT RF Function Using RF Test Tool for the ATM5/e

Figure 6-1 - Calibration iterations in RF Tool

Figure 6-2 - Calibration result in RF Tool

Figure 7-1 - 32 kHz calibration

Figure 9-1 - BTCS FCC/CE Test for GFSK

Figure 9-2 - BTCS FCC/CE Test for ASK

## List of Tables

Table 2-1 - Supported ATM2/ATM3 SoCs and EVKs

Table 2-2 - Supported ATM33/e SoCs and EVKs

Table 2-3 - Supported ATM34/e SoCs and EVKs

Table 2-4 - Supported ATM5/e SoCs and EVKs

Table 4-1 - Radio Test Descriptions

## Acronyms and Abbreviations

Acronyms	Definition
ATM2	ATM2201 ATM2202 ATM2221 ATM2231 ATM2251
ATM3	ATM3201 ATM3202 ATM3221 ATM3231
ATM33/e	ATM3325 ATM3330 ATM3330e
ATM34/e	ATM3405 ATM3430e
ATM5/e	ATM5305 ATM5205 ATM5305/e
Bluetooth LE	Bluetooth Low Energy
EVB	Evaluation Board
EVK	Evaluation Kit
SDK	Software Development Kit
SoC	System on Chip

## 1. Overview

This document provides instructions on how to install and operate the Atmosic RF Test Tool to test the following functions:

- Tx and Rx RF performance, including Tx output power and Rx sensitivity measurements.
- FCC/CE pretest and certification, including BTCS (Bluetooth Channel Sounding) Tests

## 2. Hardware and Software Requirements

The RF tool supports the following devices:

- ATM2/ATM3 series
- ATM33/e series
- ATM34/e series
- ATM5/e series

### 2.1 Supported EVK

There are multiple versions of the ATM2, ATM3, ATM33/e, ATM34/e and ATM5/e EVKs based on the specific device and package configuration. See the Tables below.

EVK	SoC Package	SoC Part Number	Kit Part Number
Evaluation Kit for ATM2202	40-pin 5x5 mm QFN	ATM2202SR	ATMEVK-M2202-02
Evaluation Kit for ATM2221	64-pin 6x6 mm QFN	ATM2221SR	ATMEVK-M2221-02
Evaluation Kit for ATM2251	37L WLCSP	ATM2251SR	ATMEVK-M2251-01
Evaluation Kit for ATM3201	40-pin 5x5 mm QFN	ATM3201SR	ATMEVK-M3201-02
Evaluation Kit for ATM3202	40-pin 5x5 mm QFN	ATM3202SR	ATMEVK-M3202-02
Evaluation Kit for ATM3221	64-pin 6x6 mm DR_QFN	ATM3221SR	ATMEVK-M3221-02

*Table 2-1 - Supported ATM2/ATM3 SoCs and EVKs*

EVK	SoC	SoC Part Number	Kit Part Number
Evaluation Kit for ATM3325	40-pin 5x5 mm QFN	ATM3325-5DCAQK	ATMEVK-3325-QK-6
Evaluation Kit for ATM3325 with extended storage	40-pin 5x5 mm QFN	ATM3325-5LCAQK	ATMEVK-3325-LQK-6
Evaluation Kit for ATM3325 WLCSP	49L WLCSP	ATM3325-5DCACM	ATMEVK-3325-CM-6
Evaluation Kit for ATM3330	56-pin 7x7 mm QFN	ATM3330-5DCAQN	ATMEVK-3330-QN-6
Evaluation Kit for ATM3330e	56-pin 7x7 mm QFN	ATM3330E-5DCAQN	ATMEVK-3330e-QN-6
Evaluation Kit for ATM3330e	56-pin 7x7 mm QFN	ATM3330E-5DCAQN	ATMEVK-3330e-QN-7

Table 2-2 - Supported ATM33/e SoCs and EVKs

EVK	SoC	SoC Part Number	Kit Part Number
Evaluation Kit for ATM3405	93-ball 4x4 mm BGA	ATM3405-5YCABV	ATMEVK-3405-YBV-5
Evaluation Kit for ATM3405	93-ball 4x4 mm BGA	ATM3405-5PCABV	ATMEVK-3405-PBV-5
Evaluation Kit for ATM3405	40-pin 5x5 mm QFN	ATM3405-5WCAQK	ATMEVK-3405-WQK-5
Evaluation Kit for ATM3405	40-pin 5x5 mm QFN	ATM3405-5PCAQK	ATMEVK-3405-PQK-5
Evaluation Kit for ATM3430e	56-pin 7x7 mm QFN	ATM3430E-5YCAQN	ATMEVK-3430e-YQN-5

Table 2-3 - Supported ATM34/e SoCs and EVKs

EVK	SoC	SoC Part Number	Kit Part Number
Evaluation Kit for ATM5305	40-pin 5x5 mm QFN	ATM5305-2NC8QK	ATMEVK-5305-NQK-2

Table 2-4 - Supported ATM5/e SoCs and EVKs

## 2.2 Supported OS

The RF Test Tool can be used with Windows 10 or Windows 11.

## 3. Environment Setup

### 3.1 Hardware Setup

A complete set of the test suite includes:

- PC (Windows 10, 11)
- ATM2/ATM3 EVK (includes Atmosic Interface Board) or
- ATM33/e EVB or
- ATM34/e EVB or
- ATM5/e EVB, with SMA RF Connector Configuration
- Type A to Micro USB cable

See the [References](#) section for additional information.

[Figure 3-1](#) shows the connection setup between the PC, the Interface board, and the EVK for the ATM2/ATM3.

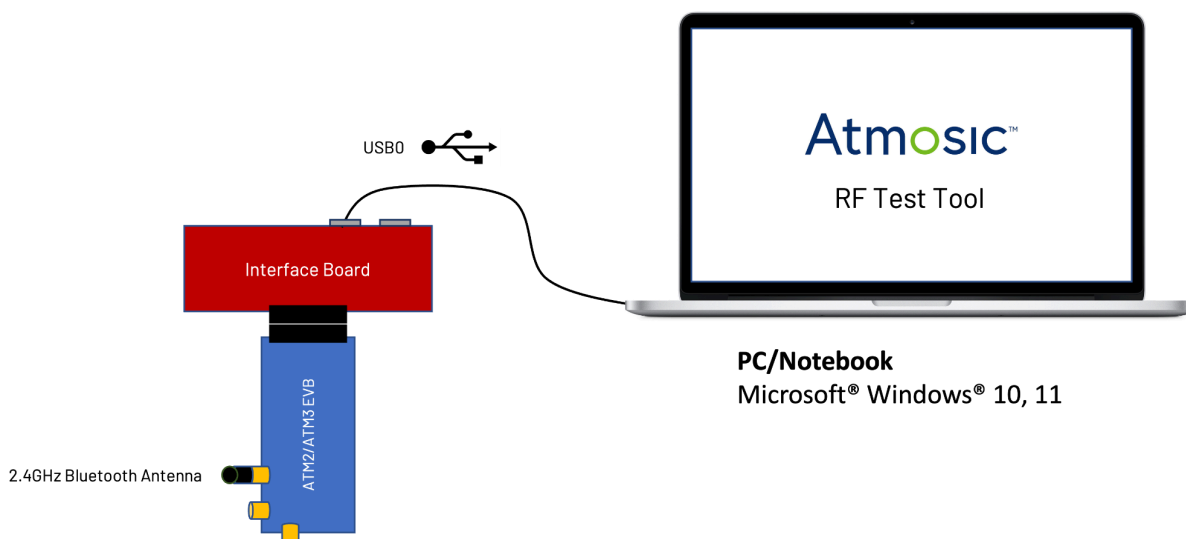

*Figure 3-1 - RF Test Tool Hardware Environment for the ATM2/ATM3 EVK with Atmosic Interface Board*

[Figure 3-2](#) shows the connection setup between the PC and the ATM33/e, or ATM34/e, Evaluation Board (EVB).

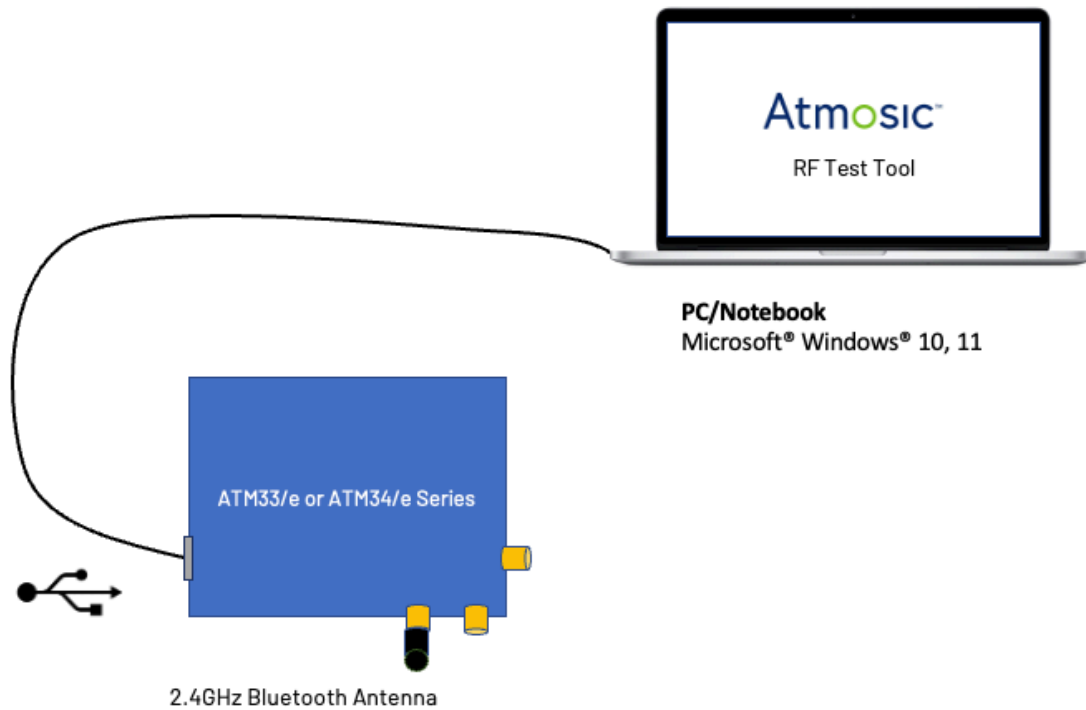

*Figure 3-2 - RF Test Tool Hardware Environment for the ATM33/e or ATM34/e EVB*

[Figure 3-3](#) shows the connection setup between the PC and the ATM5/e Evaluation Board (EVB).

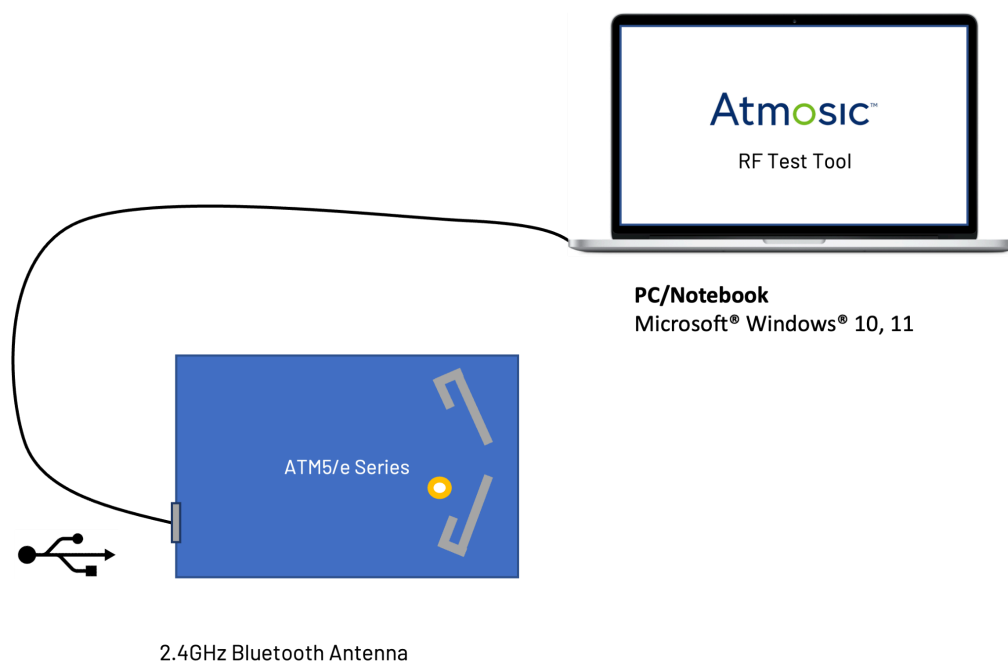

Figure 3-3 - RF Test Tool Hardware Environment for the ATM5/e EVB

### 3.1.1 Antenna Configurations on ATM5/e EVB

ATM5/e EVB has on-board PCB antennas, and also provides the SMA RF connector option for conducted RF testing.

By default, the ATM5/e EVB is configured to use the on-board PCB antennas. To change the configuration to the SMA RF connection, the following modifications are required:

- Install an SMA RF connector on EVB if it is not installed. The recommended SMA connector is TE Connectivity 5-1814832-2 SMA, as this connector provides standoff on the ground pins to avoid interference with the RF traces.
- Move the 27 pF capacitor from C86 to C65. This changes the active RF path from the on-board PCB antenna to the SMA RF connector.

For Tx Test and Rx conducted RF Tests, the test equipment connects to the SMA connector on EVB.

For the DUT Radiated TX/RX Function Test, the on-board PCB antenna configuration should be used. This can be achieved by moving the 27 pF capacitor from C65 back to C86.

## 3.2 Setup Software

- The tool is available at the Atmosic website at <https://atmosic.com/software-apps/>.
  - Tools -> RF Test Tools

### 3.2.1 Install WinUSB Driver Using Zadig

This Zadig tool is used to check and install the correct WinUSB driver needed for the Atmosic EVKs. This step is not required if the system has already been installed with the Atmosic SDK and RDI driver.

Windows Administrator privileges are required for replacing a driver. Zadig can be obtained from:

<https://github.com/pbatard/libwudi/releases>

At the time of this writing, the latest version -- 2.9 -- can be obtained using the following direct link: <https://github.com/pbatard/libwudi/releases/download/v1.5.1/zadig-2.9.exe>

To replace the driver:

- 1) From the **Options** menu of Zadig, click **List all devices**.
- 2) From the drop-down menu, find the **BULK interface** or **Atmosic RDI USB** corresponding to the Atmosic EVB. It should show **jlink (v...)** or **FTDIBUS (v ...)** as the current driver on the left.
- 3) Select **WinUSB (v...)** as the replacement on the right.
- 4) Click **Replace Driver**.

Refer to [Figure 3-4](#) and [Figure 3-5](#).

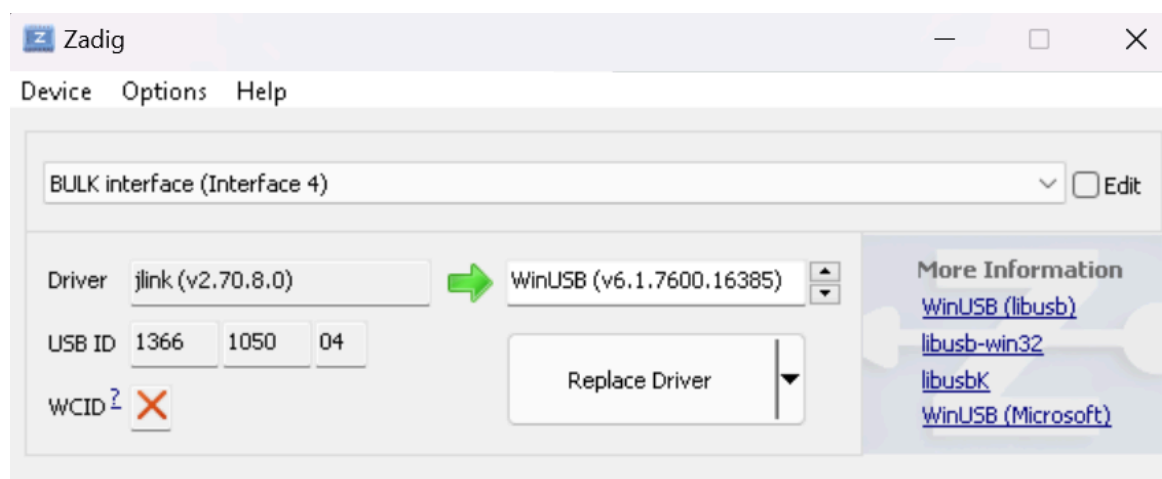

Figure 3-4 - Replace Driver for ATM33/e or ATM34/e Using Zadig

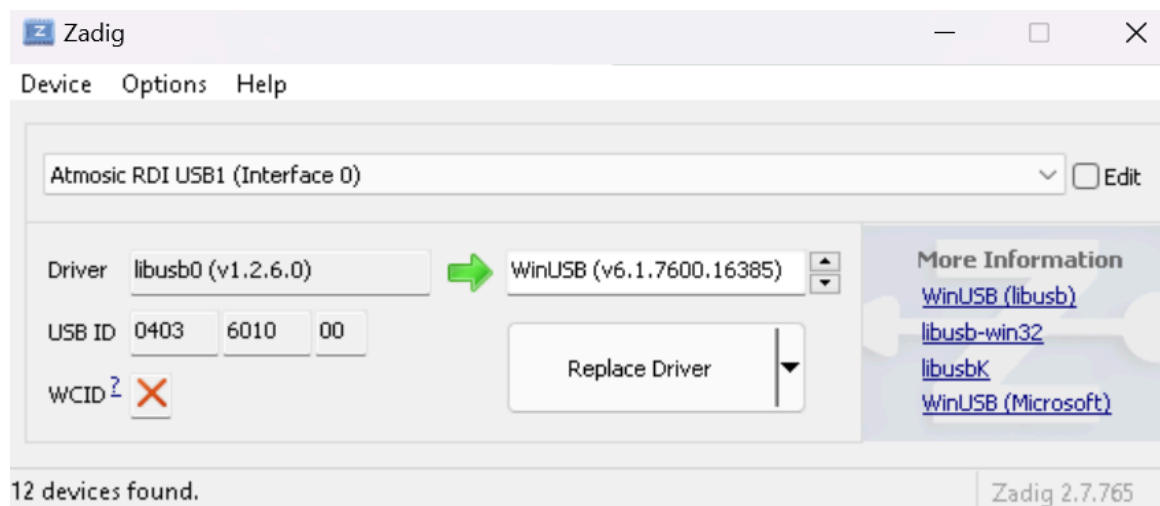

Figure 3-5 - Replace Driver for ATM2 or ATM3 Using Zadig

Verify the successful installation of WinUSB by accessing the Windows Device Manager and confirming it is the **BULK interface** driver rather than the **J-Link driver**. (In Device Manager, expand the category **Universal Serial Bus devices** and look for the **BULK interface**.)

### 3.2.2 Program Firmware

For all devices, double-click on the `program_by_openocd.bat` file in the RF Tool folder to execute, then follow the menu to select the platform to program the FW as shown in [Figure 3-6](#).

The console will guide you through the selection of the right firmware images for the different boards. See [Figure 3-7](#).

```

.....
Select [0-3] to program flash code, or 4 to exit
.....
.
0 - ATMx2xx-x1x
1 - ATM33xx-5

```

```

2 - ATM34xx-5
3 - ATM5xxx-2
4 - exit
.
Type number then press ENTER:

```

Figure 3-6 - Console to select the platform

```

.....
Select [0-6] to program HCI_vendor flash code, or 7 to exit
.....
.
0 - ATMEVK_3325_LQK
1 - ATMEVK_3325_QK
2 - ATMEVK_3325_TAG
3 - ATMEVK_3325_CM
4 - ATMEVK_3330_QN
5 - ATMEVK_3330e_QN
6 - ATMEVK_3330e_QN_7
.
Type 0, 1, 2, 3, 4, 5, 6, 7 then press ENTER:

```

Figure 3-7 - Console to select the EVB.

### 3.2.3 Launch RF Test Tool

Double-click on the `runui.bat` file in the RF Test Tool folder to execute after the DUT is powered on properly, as [Figure 3-8](#).











 fw_image	3/9/2022 12:03 AM	File folder	
 mpf.bat	3/9/2022 12:03 AM	Windows Batch File	2 KB
 notice_matplot.txt	3/9/2022 12:03 AM	Text Document	3 KB
 notice_numpy.txt	3/9/2022 12:03 AM	Text Document	2 KB
 notice_pyinstaller_3.5.txt	3/9/2022 12:03 AM	Text Document	19 KB
 notice_pyserial.txt	3/9/2022 12:03 AM	Text Document	2 KB
 notice_python_3.7.txt	3/9/2022 12:03 AM	Text Document	3 KB
 README	3/9/2022 12:03 AM	File	7 KB
 rftool.exe	3/9/2022 12:05 AM	Application	36,474 KB
 runui.bat	3/9/2022 12:03 AM	Windows Batch File	1 KB

Figure 3-8 - `runui.bat` File in the RF Test Tool Folder

### 3.3 UART Ports

For the ATM2/ATM3, connect the EVB to the interface board:

- Plug the USB cable into USB0 (port J6) of the interface board (part of the Evaluation Kit ) as shown below. Do not plug a second USB cable into USB1 (port J5) of the interface board.
- Plug the other end of the USB cable into the Windows computer, and Windows will install the FTDI USB-to-serial driver automatically. After the driver is installed, the device shows as a COM port in the Windows Device Manager. See [Figure 3-9](#)

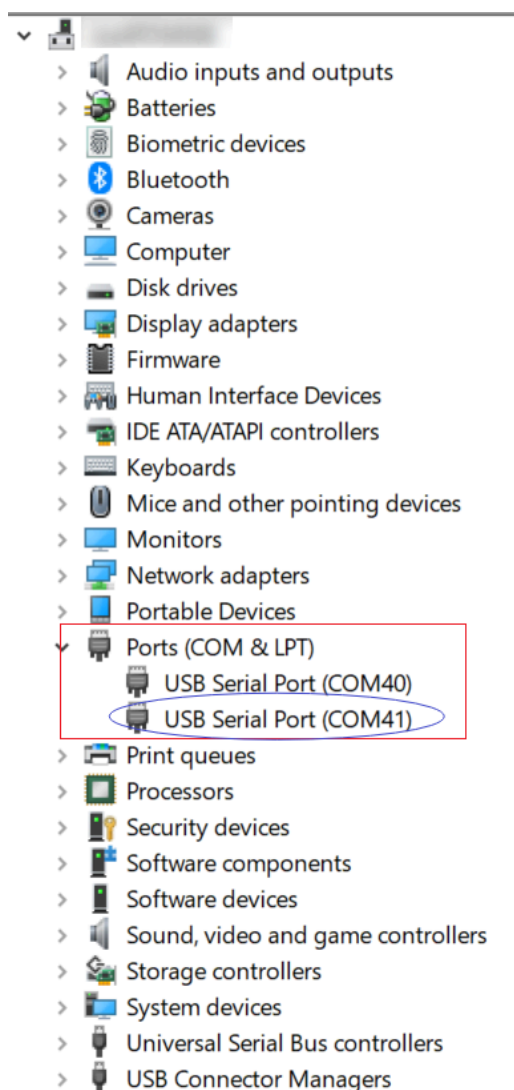

Figure 3-9 - New COM Ports from the Interface Board of ATM2/ATM3 EVK

For the ATM33/e or ATM34/e, after connecting the USB connector to the Windows laptop, there are two USB ports from the JLink CDC UART ports, as shown in [Figure 3-10](#).

One is the console output, and the other is the HCI interface port working with the RF Test Tool.

For the ATM5, after connecting the USB connector to the Windows laptop, there are three USB ports from the FTDI UART ports, as shown in [Figure 3-11](#).

The first one is the console output, and the second is the HCI interface port working with the RF Test Tool. The third is reserved.

The HCI interface port uses a 460800 baud rate for ATM2/ATM3, and 2000000 for ATM33ATM/34/ATM5.

RF Test Tool will have the interface to select COM<N>, where <N> is the COM port sequence number, depending on the Windows OS.

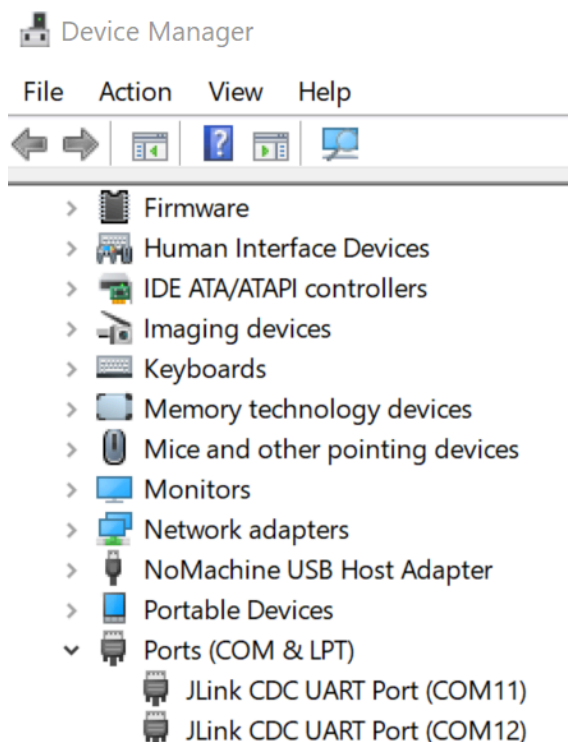

*Figure 3-10 - New COM Ports from the ATM33/e and ATM34/e EVK*

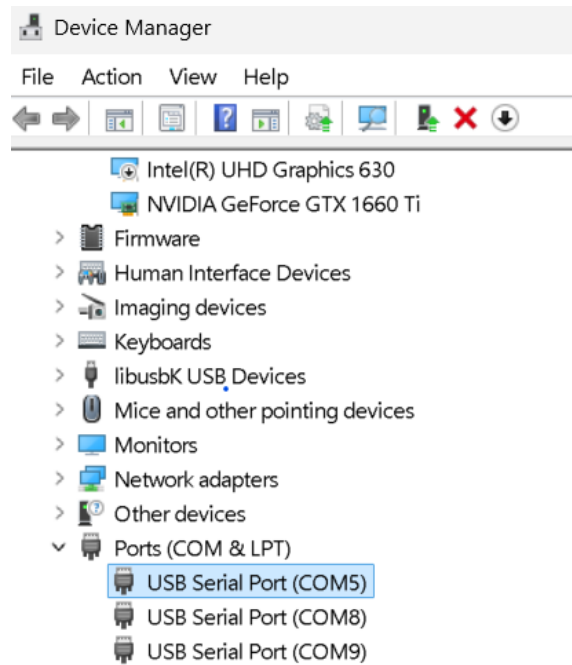

Figure 3-11 - New COM Ports from the ATM5/e EVK

### 3.4 Running the RF Test Tool

Connect the ATM2/ATM3, ATM33/e, ATM34/e, or ATM5/e EVK to a Windows laptop and execute `runui.bat`.

Command window pops up:

```
C:\RFtool\rftool_v1_6_16_2>rftool --gui
Main Thread 14712
[Warn]2025-05-19 not find .ini(AtmosicRFTool.ini) file
[Trace]2025-05-19 call enum_comport
[Trace]2025-05-19 Device-COM5, description-JLink CDC UART Port (COM5)
[Trace]2025-05-19 Device-COM6, description-JLink CDC UART Port (COM6)
```

Select the correct platform. Select the correct baud rate for the COM port. The default baud rate is configured as `460800/2000000` bps for the prebuilt HCI\_vendor firmware

image. Select a different baud rate if you have a different setting on a customized image. Click **Open COM** of RF Test Tool GUI to connect to the DUT. Then click the **Radio Test** item to enter the parameter setting windows as shown in [Figure 3-11](#).

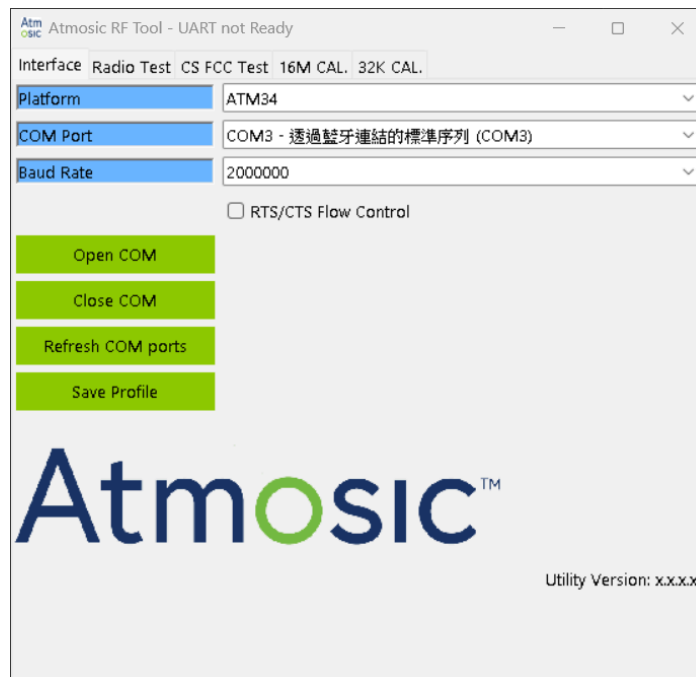

*Figure 3-12 - RF Test Tool Interface Setting*

Switch to the Radio Test Tab and click the Reset button on the RF Test Tool GUI.

If the command window shows that the Reset command was successful, you can control the EVK via the Atmosic RF Test Tool as shown in [Figure 3-12](#).

If the command window does not show the successful message, close the RF Test Tool and re-open it to try another UART COM port.

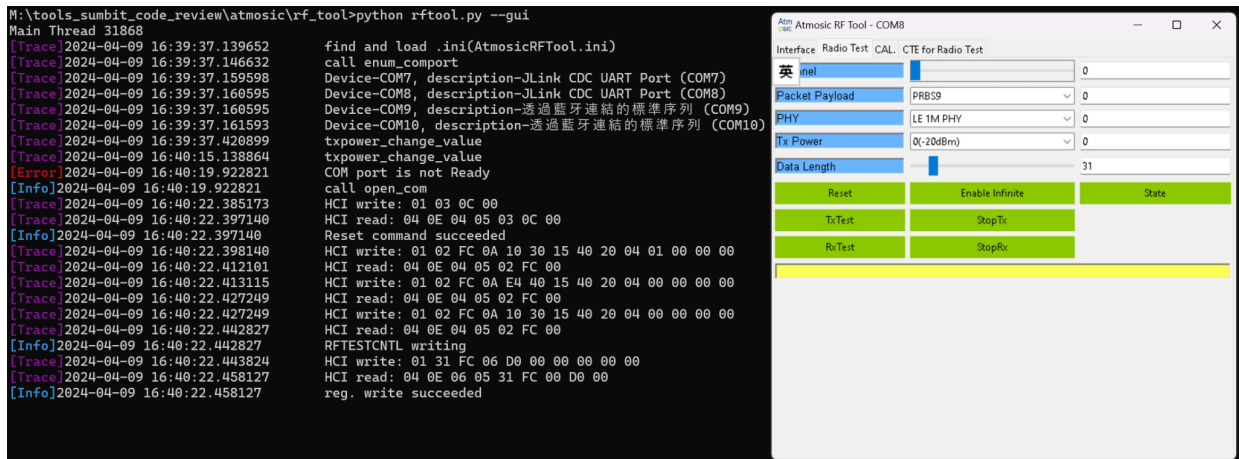

Figure 3-13 - The successful message of resetting the EVB

## 4. RF Test Functions

The RF Test Tool can control the ATM2/ATM3, ATM33/e, ATM34/e or ATM5/e devices to enter Tx test mode or Rx test mode.

The Tx test includes three modes:

- Burst Tx mode
- Infinite Tx mode
- Single tone mode

Rx test mode supports counting the number of packets received through appropriate settings.

[Figure 4-1](#) shows the RF Test Tool user interface and test items. Detailed descriptions of the test items are in [Table 4-1](#).

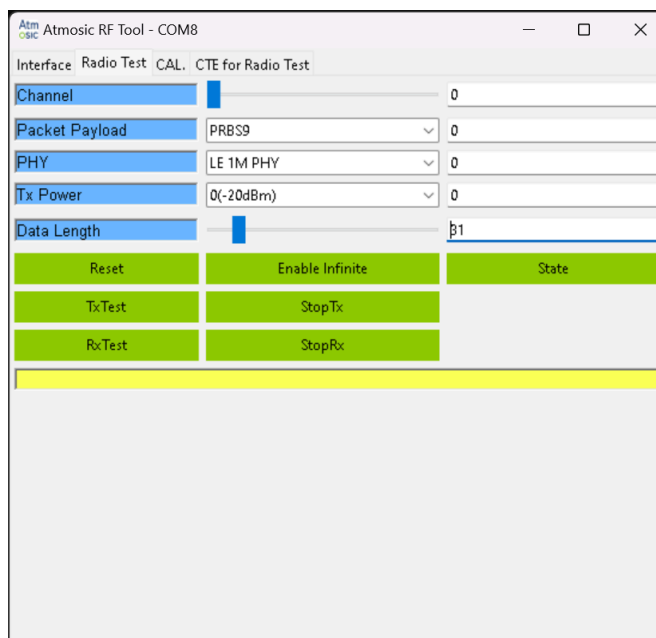

Figure 4-1 - RF Test Tool User Interface and Test Items

Name	Description	Notes
Channel	Bluetooth LE RF channel	There are 40 channels from CH0 (2402 MHz) to CH39 (2480 MHz). It can be adjusted by typing or by using the slider.
Packet Payload	Bluetooth LE standard packet payload format	Packet Payload includes: PRBS9/ 11110000 /10101010/ PRBS15/ 11111111/00000000/00001111/01010101
PHY	RF PHY	RF PHY includes: LE 1M PHY/ LE 2M PHY/ LE Coded PHY(S=2)/ LE Coded PHY(S=8) / Single Tone
Tx Power	Tx output power setting	The Tx output power level includes: 10 dBm/ 8 dBm/ 6 dBm/ 4 dBm/ 2 dBm/ 0 dBm/ -2 dBm/ -4 dBm/ -6 dBm / -8 dBm/ -10 dBm/ -20 dBm
Data Length	Payload length	The payload length range is from 1 to 255. It can be adjusted by typing or by using the slider
Reset	HCI reset command	HCI reset command: 0x01030C00
Enable Infinite (Disable Infinite)	Enable/Disable Infinite Tx mode	Enable or disable Infinite Tx mode. With this button, all the PHY settings can be defined as the “Infinite Tx mode” or “Burst Tx mode”.
State	Burst Tx mode or	Display the infinite state in the command window.

Name	Description	Notes
	Infinite Tx mode	Infinite Tx mode, show “infinite is 1”. Burst Tx mode, show “infinite is 0”.
TxTest	Turn on the Tx function	Start transmitting the RF signal
StopTx	Turn off the Tx function	Stop transmitting the RF signal
RxTest	Turn on the Rx function	Start receiving the RF signal
StopRx	Turn off the Rx function	Stop receiving the RF signal

*Table 4-1 - Radio Test Descriptions*

## 4.1 Tx Test

Three modes are supported in the Tx Test:

- Burst Tx mode
- Infinite Tx mode
- Single tone mode

[Figure 4-2](#), [Figure 4-3](#) and [Figure 4-4](#) show the ATM2/ATM3 EVK and ATM33/e or ATM34/e or ATM5/e EVK Tx test environment, respectively.

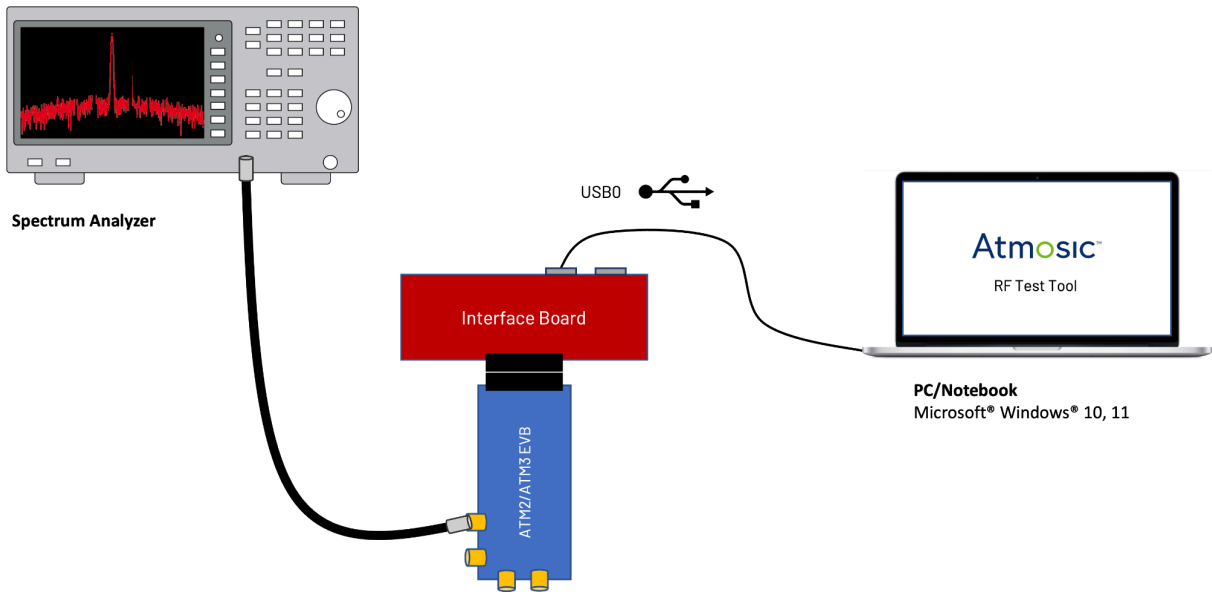

Figure 4-2 - ATM2/ATM3 EVK Tx Test Environment Setting

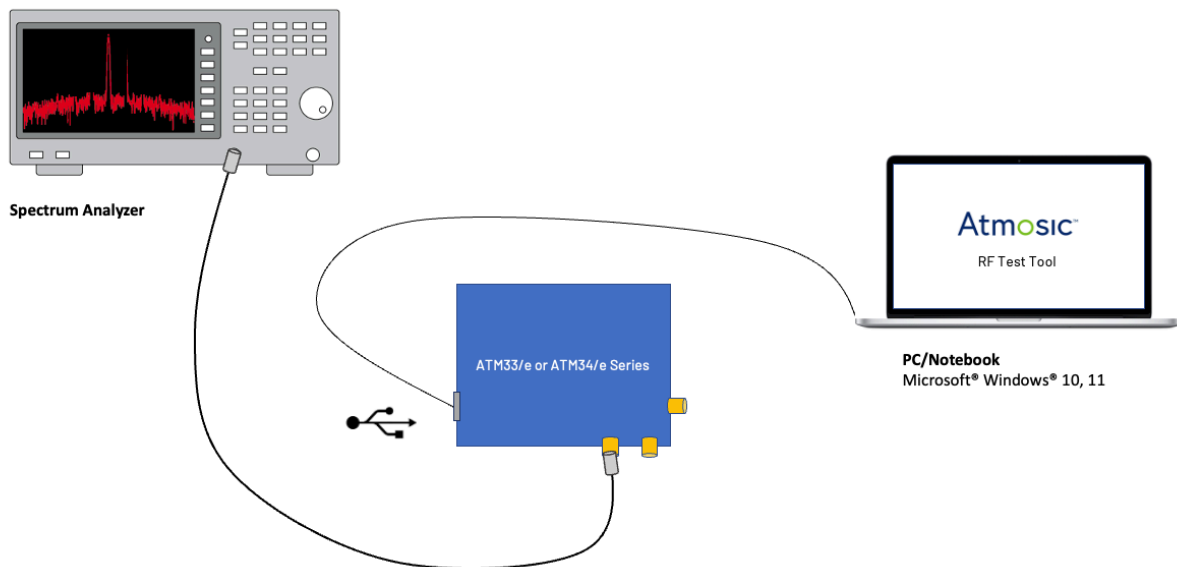

Figure 4-3 - ATM33/e or ATM34/e EVK Tx Test Environment Setting

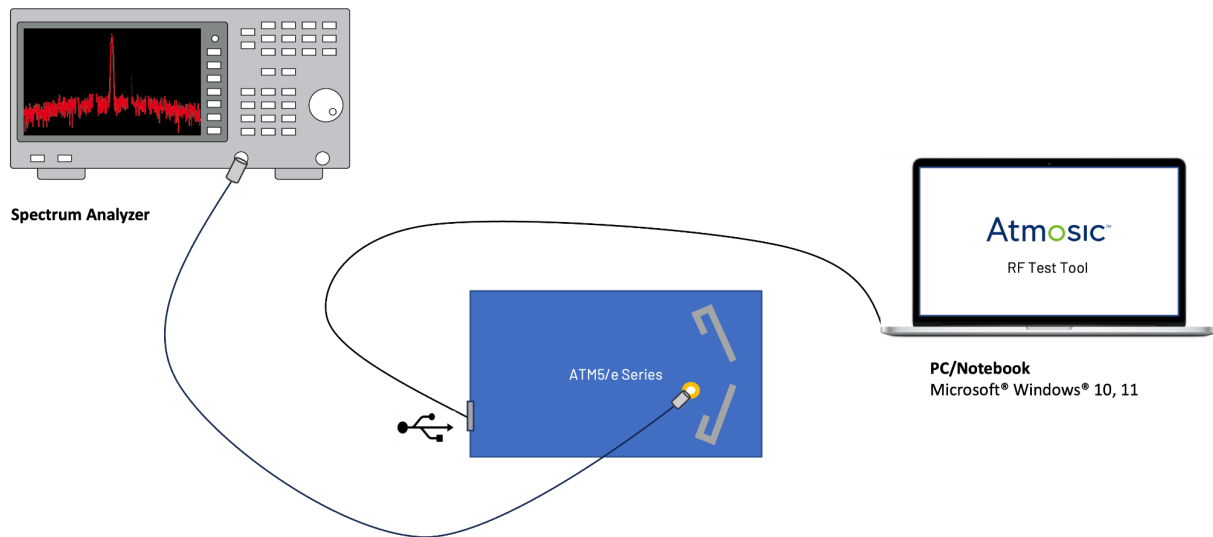

Figure 4-4 - ATM5/e EVK Tx Test Environment Setting

#### 4.1.1 Burst Tx Mode

In the default setting, when TxTest is selected, the burst-type modulation signal (duty cycle) will be sent to the RF port. Select an RF channel, RF PHY, Tx power level, and data length before pressing the TxTest button.

To change the transmission settings, first press StopTx to stop the RF signal transmission, then select a new transmission setting.

#### 4.1.2 Infinite Tx Mode

- Select **Enable Infinite** to enable the Infinite Tx mode. When TxTest is selected, the continuous modulation signal (endless packet) will be sent to the RF port.
- Select an RF channel, RF PHY, Tx power level, and data length before pressing the TxTest button.
- To change the transmission settings, first press StopTx to stop the RF signal transmission, then select a new transmission setting.

### 4.1.3 Single-Tone Transmission

- Select the PHY setting and choose `Single Tone`. When `TxTest` is selected, the continuous single tone without a modulation signal will be sent to the RF port.
- Select an RF channel and Tx power level before pressing the `TxTest` button.
- To change the transmission settings, first press `StopTx` to stop the RF signal transmission, then select a new transmission setting.

## 4.2 Rx Test

### 4.2.1 Rx Mode

- Select `RxTest` to enable the Rx mode.
- Select an RF channel, RF PHY before pressing the `RxTest` button.
- To change the Rx settings, first press `StopRx` to disable the Rx mode, then select new Rx settings.

## 5. Check the DUT RF Function Using the RF Test Tool

To check the Device Under Test (DUT) RF function without a Bluetooth LE tester, prepare a reference unit, such as the ATM3330e EVK, and a DUT.

Open two instances of RF Test Tool on the same PC, then control the reference unit and the DUT on separate instances.

[Figure 5-1](#), [Figure 5-2](#), and [Figure 5-3](#) illustrate the test environments for the ATM2/ATM3, ATM33/e, ATM34/e and ATM5/e, respectively.

For ATM5/e EVB, on-board PCB antenna configuration should be used in DUT RF Function Test. Please refer to [Antenna Configurations on ATM5/e EVB](#) for details.

Set the reference unit into Burst Tx mode to verify the DUT in Rx mode. Then, swap the test to set the reference unit into Rx mode to verify the DUT in Burst Tx mode.

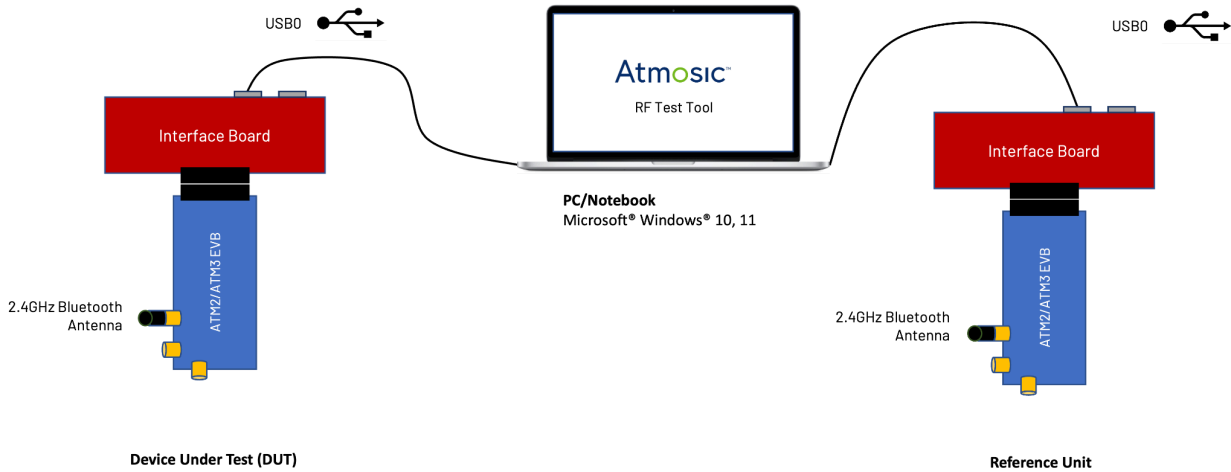

Figure 5-1 - Test Environment to Check DUT RF Function Using RF Test Tool for the ATM2/ATM3

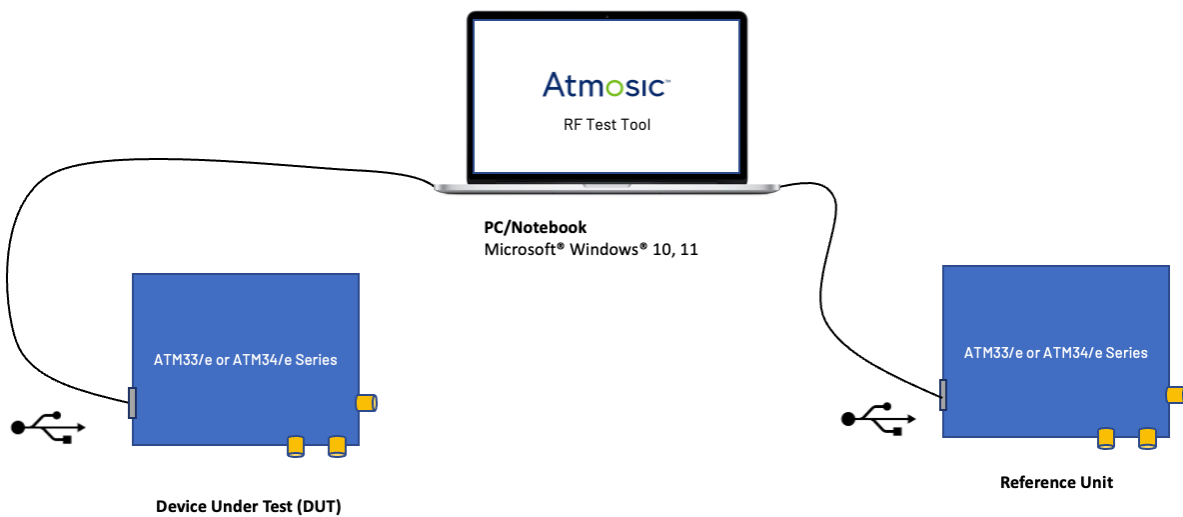

Figure 5-2 - Test Environment to Check DUT RF Function Using RF Test Tool for the ATM33/e or ATM34/e

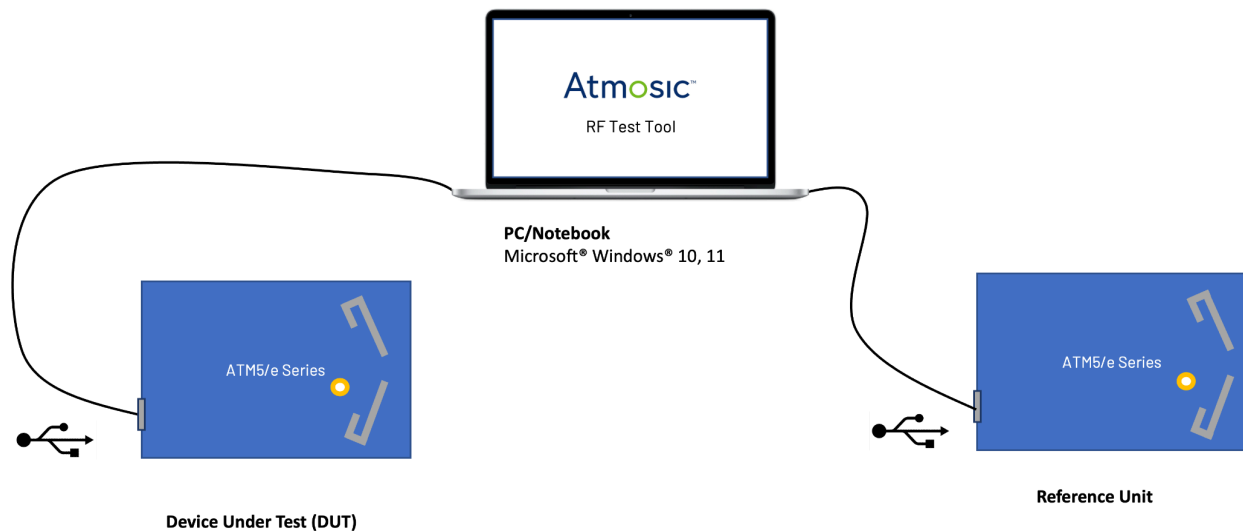

Figure 5-3 - Test Environment to Check DUT RF Function Using RF Test Tool for the ATM5/e

## 6. 16 MHz Crystal Calibration Using RF Test Tool

The 16 MHz crystal is used in Bluetooth LE devices. Bluetooth devices use a crystal oscillator to generate a stable reference frequency for the system clock. The crystal's frequency needs to be accurately calibrated to ensure that the Bluetooth device's radio signals are transmitted and received at the correct frequency.

This tool also provides a feature to aid the calibration flow. The setup is the same environment as the Tx Test section. Enter the CAL. page in the tool, input the channel you would like to calibrate, and the tool will pop up a window to guide you through the process. You may need to input the frequency bias you observe from the spectrum analyzer in several iterations. See [Figure 6-1](#).

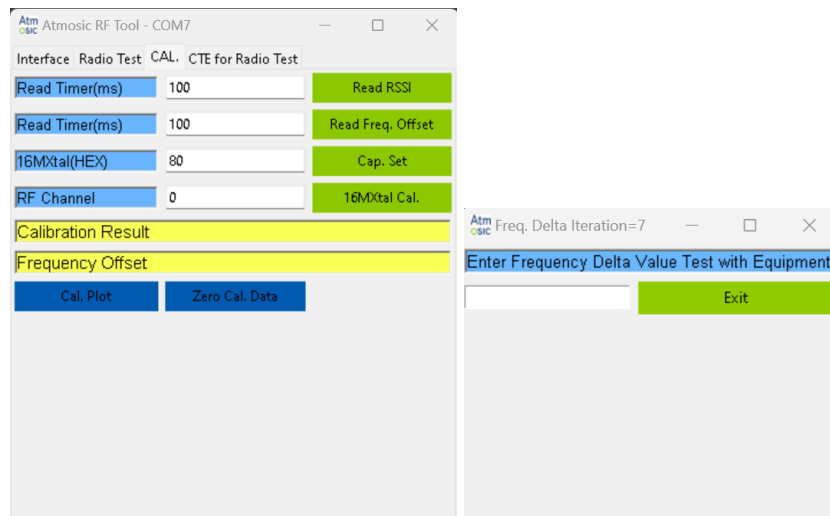

Figure 6-1 - Calibration iterations in RF Tool

Once the iterations are done, if you are satisfied with the calibration result, you can write back the calibration adjustment parameter the tool suggests by inputting the value and clicking Cap. Set. See [Figure 6-2](#).

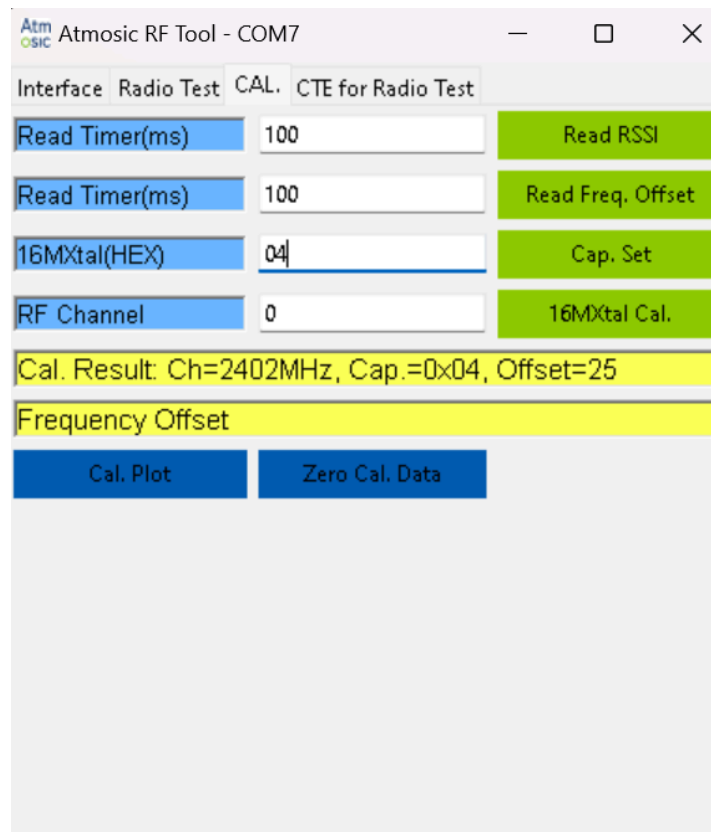

Figure 6-2 - Calibration result in RF Tool

## 7. ATM33/ATM34 32 kHz Crystal Calibration

This tool also provides a feature to aid the 32.768 kHz crystal calibration flow. The signal can be observed from a spectrum analyzer by measuring the 32.768 kHz clock signal from the pin defined in the PIN Sel assignment setting. Click the **Pin Out Set** button after selecting the available target pin, which may vary depending on the design. The calibration value ranges from 0x00 to 0x1F (default is 0x1B). Click the **Cap. Set** button after entering the value up/down during the calibration until the signal seen at the spectrum analyzer is centered correctly at 32.768 KHz.

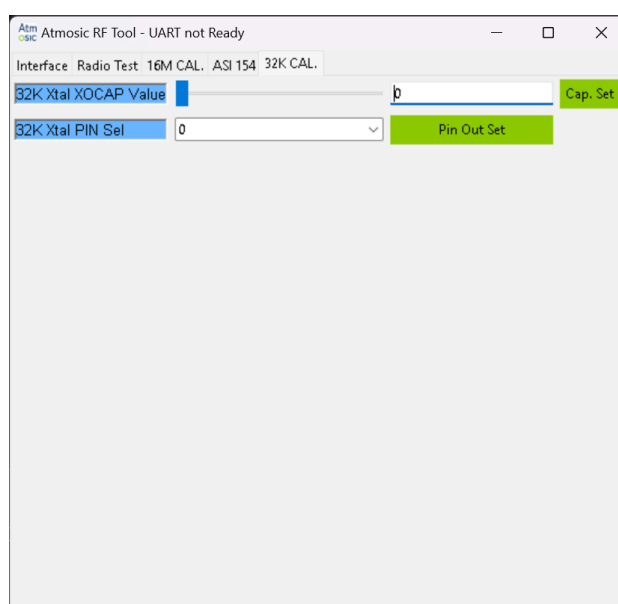

Figure 7-1 - 32 kHz calibration

## 8. Change UART0 Pins

The UART0 pins are configurable. If your board design is different from the default settings, follow the instructions below to change it for different SDK environments.

### 8.1 Change UART0 Pins for Atmosic Bare Metal SDK

Modify the UART0 configuration in the makefile under the hci\_vendor folder to change the default setting. NOTE: RTS/CTS is not required.

```
CFLAGS += -DPIN_UART0_TX=19 \  
         -DPIN_UART0_RX=28 \  
         -DPIN_UART0_RTS=17 \  
         -DPIN_UART0_CTS=16 \  
         -DHCI_UART_BAUD=115200 \  
         \
```

### 8.2 Change UART0 Pins for Zephyr

Modify the UART0 configuration in BOARD.dts under the boards folder to change the default setting.

```
&uart0 {  
    rx-pin = <30>;  
    tx-pin = <15>;  
    rts-pin = <13>;  
    cts-pin = <12>;  
};
```

Upon completion of the changes, utilize the SDK environment to flash the boards directly, instead of using program\_by\_openocd.bat to load the firmware. Windows may re-detect the COM ports, so be sure to refresh the list as shown in [Figure 3-11](#).

## 9. ATM34 Bluetooth Channel Sounding FCC/CE Test

This tool facilitates FCC/CE certification testing for the BTCS (Bluetooth Channel Sounding) feature present on ATM34 chips. It offers a testing interface compatible with various channels and modes.

The required test channels range from 2 to 76, excluding channels 23, 24, and 25.

The certification testing mandates the inclusion of GFSK 1M/2M and the ASK tone for Channel Sounding Test Mode 2.

The GFSK part is similar to the BLE fixed-frequency transmission for 1M and 2M PHY. When testing with the GFSK part, the operation steps are the same as in the Radio Test tab. See [Figure 9-1](#).

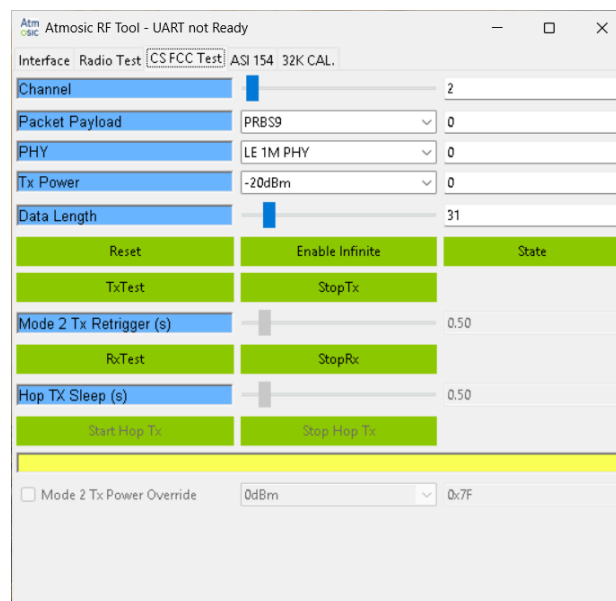

Figure 9-1 - BTCS FCC/CE Test for GFSK

For the ASK tone testing in Channel Sounding Test Mode 2, you can use either a single channel or hop across the full frequency range. The transmit (Tx) power is set to its maximum value by the default setting in the programmed firmware. To override the default power setting, select the desired value by checking the **Mode 2 Tx Power Override** option. The duration for both single-channel and hopping tests is 0.5 seconds. Specifically, in a single-channel test, the signal is retriggered at fixed 0.5-second intervals. For a hopping test, each frequency hop is maintained for 0.5 seconds. See [Figure 9-2](#).

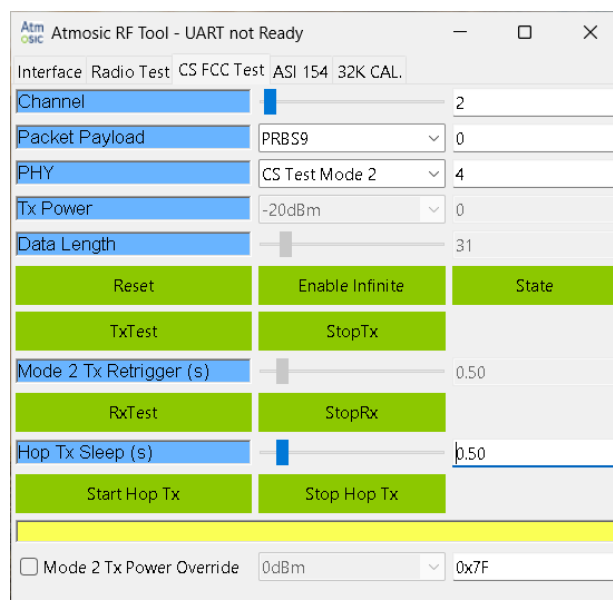

Figure 9-2 - BTCS FCC/CE Test for ASK

## References

Title	Document Number
EVK User's Guide for ATMx301/ATMx202	ATMx201-UG
EVK User's Guide for ATMx221	ATMx221-UG
ATM33/e Series Evaluation Kit User Guide	ATM33_e-UGEVK
ATM34/e Series Evaluation Kit User Guide	6441-xxxx-xxxx
	Link
<a href="#">Zadig Driver</a>	<a href="#">Version 2.4</a>

## Revision History

Date	Version	Description
April 27, 2026	0.67	Update for RF Tool version 1.6.16.8. No major update on the tool side but adding prebuilt images and mapping the register control to work with ATM53.
March 25, 2026	0.66	Update for RF Tool version 1.6.16.7 and 1.6.16.6 Updated <a href="#">Change UART0 Pins</a> Added <a href="#">ATM34 Bluetooth Channel Sounding FCC/CE Test</a> Editorial update, including chapter/section numbering
Dec 30, 2025	0.65	Update for RF Tool version 1.6.16.5 Update ATM33/34 Zephyr images Update ATM2/ATM3 Baremetal images
Aug 18, 2025	0.64	Update for RF Tool version 1.6.16.4 Add ATM33/34 Zephyr images
May 22, 2025	0.63	Update for RF Tool version 1.6.16.3 Add 32 KHz Crystal calibration for ATM33/34
April 22, 2024	0.62	Update for RF Tool version 1.6.16.1. Remove plotting Rx NOP statistics and support ATM34/e 802.15.4 RF Test.
March 17, 2023	0.60	Updated for RF Tool version 1.6.5. Updated <a href="#">Table 2 - Supported ATM33/e SoCs and EVKs</a> , <a href="#">Setup Software</a> , <a href="#">Install WinUSB Driver Using Zadig</a> , <a href="#">Program Firmware</a> , <a href="#">UART Ports</a> , <a href="#">Burst Tx Mode</a> , <a href="#">Infinite Tx Mode</a> , and added <a href="#">16 MHz Crystal Calibration Using RF Test Tool</a> sections.
March 21, 2022	0.54	Updated for RF Tool version 1.6.0. throughout this document.
August 23, 2021	0.53	Updated baud rate in <a href="#">Figure 10 - RF Test Tool Interface Setting</a> .
April 14, 2021	0.52	Updated format, no content change.
December 2, 2020	0.51	Corrected typos.
June 15, 2020	0.50	Initial version created.



## ATMOSIC TECHNOLOGIES – DISCLAIMER

This product document is intended to be a general informational aid and not a substitute for any literature or labeling accompanying your purchase of the Atmosic product. Atmosic reserves the right to amend its product literature at any time without notice and for any reason, including to improve product design or function. While Atmosic strives to make its documents accurate and current, Atmosic makes no warranty or representation that the information contained in this document is completely accurate, and Atmosic hereby disclaims (i) any and all liability for any errors or inaccuracies contained in any document or in any other product literature and any damages or lost profits resulting therefrom; (ii) any and all liability and responsibility for any action you take or fail to take based on the information contained in this document; and (iii) any and all implied warranties which may attach to this document, including warranties of fitness for particular purpose, non-infringement and merchantability. Consequently, you assume all risk in your use of this document, the Atmosic product, and in any action you take or fail to take based upon the information in this document. Any statements in this document in regard to the suitability of an Atmosic product for certain types of applications are based on Atmosic's general knowledge of typical requirements in generic applications and are not binding statements about the suitability of Atmosic products for any particular application. It is your responsibility as the customer to validate that a particular Atmosic product is suitable for use in a particular application. All content in this document is proprietary, copyrighted, and owned or licensed by Atmosic, and any unauthorized use of content or trademarks contained herein is strictly prohibited.

Copyright ©2020-2026 by Atmosic Technologies. All rights reserved. Atmosic logo is a registered trademark of Atmosic Technologies Inc. All other trademarks are the properties of their respective holders.



Atmosic Technologies | 2130 Gold Street #200 | San Jose, CA 95002  
[www.atmosic.com](http://www.atmosic.com)