

ATM34/e Series Evaluation Kit

User Guide

SUMMARY: This guide provides an overview of the ATM34/ATM34e Wireless SoC Series Evaluation Kit (EVK), power-up instructions, and hardware configurations.

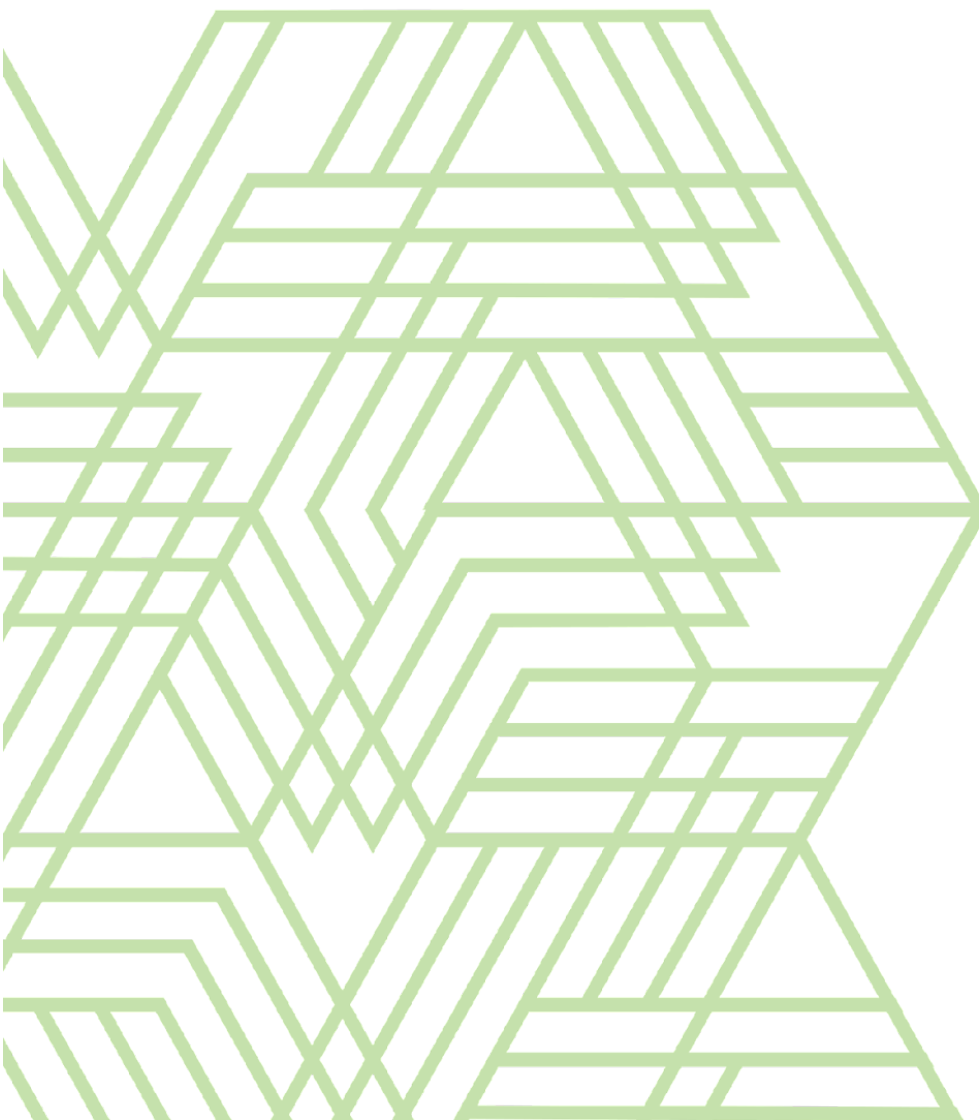

Atmosic™

ATM34 Series Evaluation Kit
June 25, 2026
6441-0198-0016

Table of Contents

| | |
|---|-----------|
| Table of Contents | 2 |
| List of Figures | 2 |
| List of Tables | 3 |
| Acronyms and Abbreviations | 4 |
| 1. Overview | 5 |
| 2. Hardware and Software Requirements | 6 |
| 2.1 Supported EVK | 6 |
| 2.2 Supported SDK | 6 |
| 3. ATM34/e EVK Description | 7 |
| 3.1 ATM3430e QFN 7x7 mm EVB Description | 7 |
| 3.2 ATM3405 BGA 4x4 mm EVB Description | 19 |
| 3.3 ATM3405 QFN 5x5 mm EVB Description | 27 |
| 4. VDDIO Voltage | 37 |
| 5. Powering on the EVB via the USB Connector | 37 |
| 6. Reconfigure the EVB | 38 |
| 7. Making Measurements with the EVB | 38 |
| Reference Documents | 40 |
| Revision History | 41 |

List of Figures

Figure 1 - ATM34/e Evaluation Kit Components

Figure 2 - ATM3430e QFN 7x7 mm Package v2.x EVB Overview

Figure 3 - ATM3430e QFN 7x7 mm Package v2.x EVB Jumper Locations

Figure 4 - ATM3430e QFN 7x7 mm Package v2.x EVB Top Silkscreen

Figure 5 - ATM3405 BGA 4x4mm Package v0.x EVB Overview

Figure 6 - ATM3405 BGA 4x4mm Package v0.x EVB Jumper Locations

Figure 7 - ATM3405 BGA 4x4mm Package v0.x EVB Top Silkscreen

Figure 8 - ATM3405 QFN 5x5 mm Package v3.x EVB Overview

Figure 9 - ATM3405 QFN 5x5 mm Package v3.x EVB Jumper Locations

Figure 10 - ATM3405 QFN 5x5 mm Package v3.x EVB Top Silkscreen

List of Tables

Table 1 - Applicable SoCs and EVKs

Table 2 - ATM3430e QFN 7x7 mm Package v2.x EVB Main Components Descriptions

Table 3 - ATM3430e QFN 7x7 mm Package v2.x EVB Jumpers Descriptions

Table 4 - ATM3430e QFN 7x7 mm Package v2.x EVB Default Configurations

Table 5 - ATM3405 BGA 4x4mm Package v0.x EVB Main Components Descriptions

Table 6 - ATM3405 BGA 4x4mm Package v0.x EVB Jumpers Descriptions

Table 7 - ATM3405 BGA 4x4mm Package v0.x EVB Default Configurations

Table 8 - ATM3405 QFN 5x5 mm Package v3.x EVB Main Components Descriptions

Table 9 - ATM3405 QFN 5x5 mm Package v3.x EVB Jumpers Descriptions

Table 10 - ATM3405 QFN 5x5 mm Package v3.x EVB Default Configurations

Acronyms and Abbreviations

| Acronyms | Definition |
|----------|--------------------------|
| ATM34/e | ATM3405 ATM3430e |
| EVB | Evaluation Board |
| EVK | Evaluation Kit |
| LDO | Low Dropout Regulator |
| OB | On Board |
| PA | Power Amplifier |
| SDK | Software Development Kit |
| SoC | System-on-Chip |

1. Overview

The EVK for ATM34/e Wireless SoC Series enables developers to:

- Evaluate ATM34/e Bluetooth Low Energy SoC features, energy harvesting functionality, and performance
- Run basic example applications from the SDK that use onboard temperature, humidity, and motion sensors
- Debug with J-Link OB debugger without using an external J-Link dongle. The Segger J-Link license is included as part of the EVB. It is a handy development and debugging tool
- Measure the ATM34/e device power consumption
- Prototype applications on the ATM34/e

This document provides an overview of the available EVKs, EVBs, power-up instructions, hardware, and Windows driver configurations.

See the [Reference Documents](#) section for related documents.

2. Hardware and Software Requirements

2.1 Supported EVK

This document is applicable to:

| EVK | SoC Package | SoC Part Number | Kit Part Number |
|---|--------------------|----------------------------------|--|
| Evaluation Kit for ATM3430e QFN 7x7 mm Package | 56-pin 7x7 mm QFN | ATM3430E-5YCAQN | ATMEVK-3430e-YQN-5 |
| Evaluation Kit for ATM3405 BGA 4x4 mm Package | 93-ball 4x4 mm BGA | ATM3405-5YCABV | ATMEVK-3405-YBV-5 |
| Evaluation Kit for ATM3405 QFN 5x5 mm Package | 40-pin 5x5 mm QFN | ATM3405-5WCAQK ATM3405-5PCAQK | ATMEVK-3405-WQK-5 ATMEVK-3405-PQK-5 |

Table 1 - Applicable SoCs and EVKs

2.2 Supported SDK

The Atmosic Zephyr OpenAir SDK can be used with the EVK. Refer to <https://github.com/Atmosic/openair> for more information.

3. ATM34/e EVK Description

ATM3430e Evaluation Board



Accessories



ATM3405 Evaluation Board



Accessories



Figure 1 - ATM34/e Evaluation Kit Components

3.1 ATM3430e QFN 7x7 mm EVB Description

[Figure 2](#) highlights some of the key components of the ATM3430e QFN 7x7 mm EVB. [Table 2](#) provides the descriptions of the labeled components.

All components, except for the CR2032-sized battery holder, are on the top side of the board.

The jumper settings as shown in the figure have been configured for typical operation where battery voltage (VBAT) for the ATM3430e is supplied by the onboard 3.0 V linear LDO regulator.

The I/O voltage (VDDIO) of the ATM3430e is internally supplied by VDDIOP. The supply voltage (VCCIO) of the EVB management processor (MK22N) and the sensors is generated by an auto-tracking circuit such that $VCCIO = VDDIO$ when $VDDIO \geq 1.72V$.

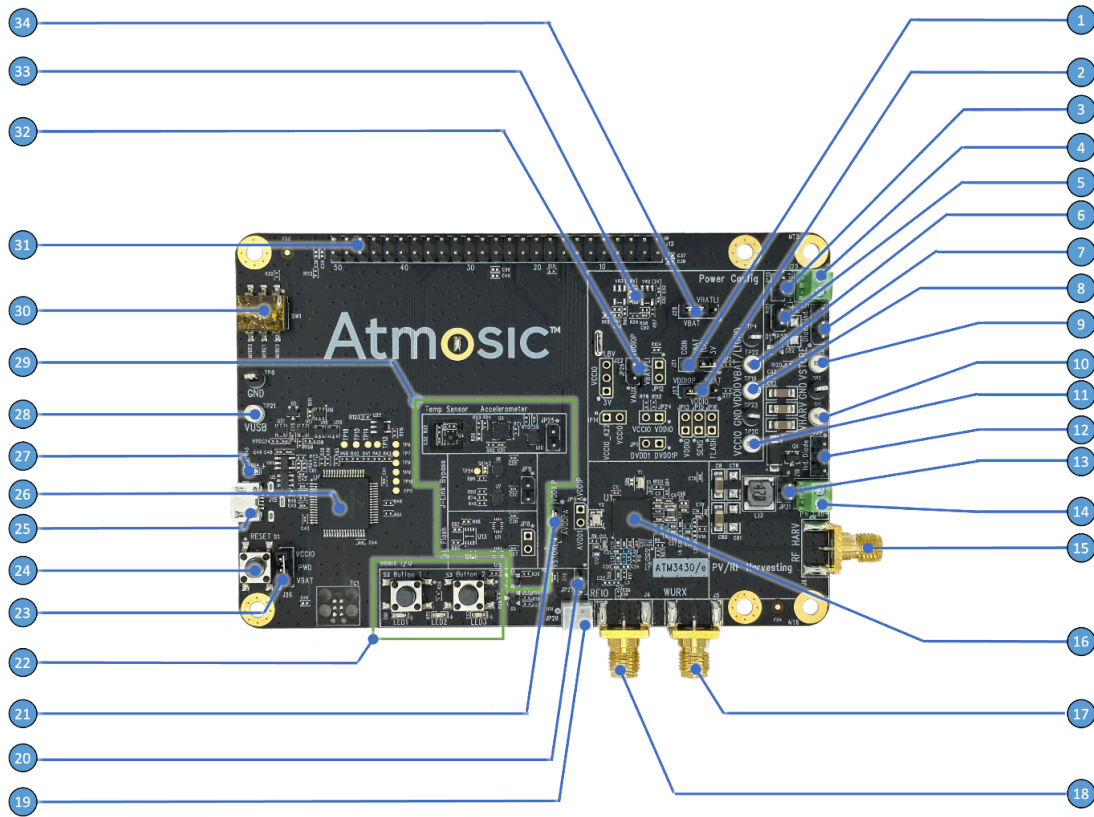

| | |
|--|--|
| 1 - VBAT(LI) Source Select Jumper (J21) | 18 - Bluetooth LE RFIO Connector (J4) |
| 2 - VDDIO Select Jumper (J23) | 19 - Antenna Control Connector (JP28) |
| 3 - Bypass measurement resistor (JP30) | 20 - LED/Button Enable Jumper (JP27) |
| 4 - Li-Ion Battery Connector (J25) | 21 - PA Supply Select Jumper (J3) |
| 5 - Inductive Charge Cir Enable (JP32) | 22 - General Purpose I/O |
| 6 - VBAT(LI) Test Point (TP22) | 23 - Reset Voltage Select Jumper (J26) |
| 7 - Diode/Inductive Charge Select (J31) | 24 - Reset Button (S1) |
| 8 - VDDIO Test Point (TP19) | 25 - Micro-B USB Connector |
| 9 - VSTORE Test Point (TP25) | 26 - EVB Management Processor (MK22N) |
| 10 - VHARV Test Point (TP1) | 27 - USB Power LED |
| 11 - VCCIO Test Point (TP20) | 28 - USB Power Test Point (TP21) |
| 12 - Diode/Inductive Charge Select (J29) | 29 - Peripherals & Enable Jumpers |
| 13 - Inductive Charge Cir Select (JP31) | 30 - DIP Switches (3) |
| 14 - PV Cell Connector (J19) | 31 - 50-Pin Expansion Header (J12) |
| 15 - For Internal Use Only (J6) | 32 - VDDIOP Disable (JP26) |
| 16 - ATM3430e | 33 - 1.8V/3.0V LDOs |
| 17 - Wake Up Receiver Connector (J5) | 34 - VBAT / VBATLI Select (J28) |

LED1: RED
 LED2: YELLOW
 LED3: BLUE

Push Button 1: (S2)
 Push Button 2: (S3)

Flash: JP8
 J-Link Bypass: JP11
 Sensors: JP25

Figure 2 - ATM3430e QFN 7x7 mm Package v2.x EVB Overview

| Item | Component | Description |
|------|--|--|
| 1 | VBAT(LI) Source Select Jumper (J21) | <ul style="list-style-type: none"> ● Select COIN if a coin cell battery is installed in the holder BT2 mounted on the back of the board, and battery operation is desired. ● Select 3 V if USB is connected and regulated 3.0 V operation (VBAT or VBATLI) is desired. ● Select neither (no jumper) if an external supply (1.1 V - 3.3 V) is connected to TP22. <p>This option is used for power profiling of ATM3430e or when a supply voltage other than 3.0 V for VBAT or VBATLI is desired.</p> |
| 2 | VDDIO Select Jumper (J23) | <ul style="list-style-type: none"> ● Select VDDIOP if internally generated 1.8 V by the ATM3430e is used for I/O voltage. <ul style="list-style-type: none"> ○ Install <u>VCCIO Select Jumper</u> J22 (see below) accordingly ● Select VBAT if an external VDDIO equal to VBAT is desired for I/O voltage. <ul style="list-style-type: none"> ○ Install <u>VCCIO Select Jumper</u> J22 (see below) accordingly ○ Install <u>JP26</u> (to connect VDDIOP to VAUX) if VDDIOP is not used to power the PA (J3) for output power greater than 4 dBm ● Select neither (no jumper) if an external supply (1.8 V - 3.3 V) is connected to TP19. <ul style="list-style-type: none"> ○ Install <u>JP26</u> (to connect VDDIOP to VAUX) if VDDIOP is not used to power the PA (J3) for output power greater than 4 dBm |
| 3 | Bypass measurement resistor JP30 | <ul style="list-style-type: none"> ● Install JP30 to bypass measurement resistor R122 for real-world operation. ● Leave JP30 open to enable current-to-voltage conversion R122 for performance measurements. |
| 4 | Li-Ion Battery Connector (J25) | <ul style="list-style-type: none"> ● Connect a Li-Ion battery or a Hybrid Supercapacitor to the board. Note that the polarity of the connector is marked in white silkscreen. ● Insert the corresponding leads of the Li-Ion battery or Hybrid Supercapacitor into the connector and secure the leads by turning the screws clockwise until it's tight. |
| 5 | Inductive Charging Circuit Enable (JP32) | <ul style="list-style-type: none"> ● Install JP32 when the Inductive Charging Circuit is used. This will short VSTORE to GND to enable the operation of this charging circuit. ● Leave JP32 open when the Diode Charging Circuit is used. |
| 6 | VBAT(LI) Test Point (TP22) | <ul style="list-style-type: none"> ● Provide external VBAT or VBATLI voltage directly to the ATM3430e, or |

| Item | Component | Description |
|------|--|--|
| | | <ul style="list-style-type: none"> When an arbitrary VBAT voltage (different from 3 V) is desired. <p>Note: When TP22 is used, no jumper should be installed on J21.</p> |
| 7 | Diode/Inductive Charging Select (J31) | <ul style="list-style-type: none"> Select “Diode” (pins 1-2) for Diode Charging Circuit. Select “Ind.” (pins 2-3) for Inductive Charging Circuit. |
| 8 | VDDIO Test Point (TP19) | <ul style="list-style-type: none"> Provide external VDDIO voltage directly to the ATM3430e. <p>Note: When TP19 is used, no jumper should be installed on J23.</p> |
| 9 | VSTORE Test Point (TP25) | <ul style="list-style-type: none"> For monitoring the harvested energy level when PV harvesting is enabled. |
| 10 | VHARV Test Point (TP1) | <ul style="list-style-type: none"> For connection to a photovoltaic (PV) cell or other energy-harvesting devices as an input. |
| 11 | VCCIO Test Point (TP20) | <ul style="list-style-type: none"> Provide external VCCIO voltage for the peripheral devices on the board instead of using the onboard VDDIO-VCCIO auto-tracking circuit or the onboard 1.8 V and 3.0 V LDOs. Used when the VDDIO of the ATM3430e is other than 1.8 V or 3 V and the VDDIO-VCCIO auto-tracking circuit is not used. This external VCCIO supply voltage needs to match the external VDDIO voltage on TP19. <p>Note: When TP20 is used, no jumper should be installed on J22, and resistor R113 should be removed.</p> |
| 12 | Diode/Inductive Charging Select (J29) | <ul style="list-style-type: none"> Select “Diode” (pins 1-2) for Diode Charging Circuit. Select “Ind.” (pins 2-3) for Inductive Charging Circuit. |
| 13 | Inductive Charging Circuit Select (JP31) | <ul style="list-style-type: none"> Install this Jumper JP31 to use the Inductive Charging Circuit. Leave JP31 open if the Diode Charging Circuit is used. |
| 14 | PV Cell Connector (J19) | <ul style="list-style-type: none"> Connect a PV Cell to the board. Note that the polarity of the connector is marked in white silkscreen. Insert the corresponding leads of the PV Cell into the connector and secure the leads by turning the screws clockwise until it’s tight. |
| 15 | RF Connector (J6) for internal use only | <ul style="list-style-type: none"> For internal use only. |
| 16 | ATM3430e | <ul style="list-style-type: none"> 7x7 mm QFN 56-pin package with center GND pad. |

| Item | Component | Description |
|------|-----------------------------------|--|
| 17 | Wake Up Receiver Connector (J5) | <ul style="list-style-type: none"> For connection to an antenna. The current matching components on the EVB are tuned for 2400 MHz and can be modified to match other frequencies, such as 900 MHz. |
| 18 | Bluetooth LE RFIO Connector (J4) | <ul style="list-style-type: none"> For connection to a 2.4 GHz antenna, or An instrument (network analyzer, spectrum analyzer, Bluetooth LE tester). |
| 19 | Antenna Control Connector (JP28) | <ul style="list-style-type: none"> Optional for Channel Sounding feature with antenna diversity. Used to power an external RF SPDT antenna switch and switch between two antennas during Channel Sounding operation. |
| 20 | LED/Button Enable Jumper (JP27) | <ul style="list-style-type: none"> Install JP27 to enable the functionality of the LEDs: <ul style="list-style-type: none"> LED1: RED LED2: YELLOW LED3: BLUE Button 1: S2 Button 2: S3 |
| 21 | PA Supply Select Jumper (J3) | <ul style="list-style-type: none"> Select nothing (no jumper) if Bluetooth LE transmit power is 4 dBm or lower. Select VDDIOP if Bluetooth LE transmit power is greater than 4 dBm. Select VSTORE only for internal use. |
| 22 | General Purpose I/O | <ul style="list-style-type: none"> 2 Buttons and 3 LEDs controlled by the GPIOs of the ATM3430e. <p>Note: JP25 needs to be installed to provide power to the 2 Buttons.</p> |
| 23 | Reset Voltage Select Jumper (J26) | <ul style="list-style-type: none"> Select VBAT if VCCIO is not available (USB is not connected). Select VCCIO if USB is connected and accurate power-down ATM3430e current measurement is required. |
| 24 | Reset Button (S1) | <ul style="list-style-type: none"> To assert PWD to the ATM3430e (pin 16) to reset the ATM3430e. |
| 25 | Micro-B USB Connector | <ul style="list-style-type: none"> Provide power to the EVB and communication to the ATM3430e. |
| 26 | EVB Management | <ul style="list-style-type: none"> Used as a translation between USB, UART, and SWD. |

| Item | Component | Description |
|------|---|--|
| | Processor (MK22N) | <ul style="list-style-type: none"> Note: the main supply voltage level (VCCIO) of this processor needs to match that of the IO supply (VDDIO) of the ATM3430e. |
| 27 | USB Power LED | <ul style="list-style-type: none"> The green LED lights up when the EVB is connected to a computer through the USB connector. |
| 28 | USB Power Test Point (TP21) | <ul style="list-style-type: none"> TP21 can be used to supply the board with an external 5 V in the case where a USB connection to the board is not available. <p>Note: TP21 should not be used concurrently with a USB connection to a host laptop.</p> |
| 29 | Peripheral & Enable Jumpers (JP8, JP11, JP25) | <p>Enable for Flash (JP8), J-Link bypass (JP11), and Sensors (JP25).</p> <ul style="list-style-type: none"> Install JP8 to enable external Flash for EVBs with the external Flash option. Install JP11 to disconnect the MK22N microcontroller I/O lines (SWD, UARTs) from the GPIOs of the ATM3430e by switching the analog switches (U7, U9). <ul style="list-style-type: none"> This option is useful for accurate power profiling of the ATM3430e without interference from the MK22N Install JP25 to enable the temperature sensor and accelerometer, and power the General Purpose I/O. <ul style="list-style-type: none"> ENS210 Temperature and Humidity Sensor Used by the demo application “HT_thermometer” or Sensor Beacon to demonstrate the ability of the ATM3430e to retrieve temperature and humidity information from the sensor to facilitate software development. <ul style="list-style-type: none"> LIS3DH Motion Sensor Used by the demo application “lis2dh12_demo” to demonstrate the ability of the ATM3430e to retrieve motion information from the sensor to facilitate software development. |
| 30 | DIP Switches (3) | <ul style="list-style-type: none"> For selecting different harvesting modes (Mode0, Mode1, Mode2) by pulling the GPIOs P11, P14, or P24 low through the resistor R32. If harvesting is not used, these switches can be ignored. |
| 31 | 50-Pin Expansion Header (J12) | <ul style="list-style-type: none"> For connection to test instruments. All the GPIOs are available by default on this header. |
| 32 | VDDIOP Disable Jumper (JP26) | <ul style="list-style-type: none"> Install this Jumper JP26 when VDDIOP is not used to power VDDIO |

| Item | Component | Description |
|------|-----------------------------|--|
| | | (J23) (see #7 above). <i>Note: Install only if VDDIOP is not used to power the PA (J3) for output power greater than 4 dBm.</i> |
| 33 | 1.8 V / 3.0 V LDOs | <ul style="list-style-type: none"> Supply voltages to the ATM3430e and other peripheral components using either 1.8 V or 3.0 V. These LDOs are powered by the USB power through the USB connector. |
| 34 | VBAT or VBATLI Select (J28) | <ul style="list-style-type: none"> Select VBAT (pins 2-3) to power the ATM3430e via the VBAT pin 20. Select VBATLI (pins 1-2) to power the ATM3430e via the VBATLI pin 28. |

Table 2 - ATM3430e QFN 7x7 mm Package v2.x EVB Main Components Descriptions

In addition to the configurable jumpers described above, there are a few other jumpers on the board that are not installed by default because they are not normally needed for typical use. All these jumpers, except J22 and JP24, are shorted by default through solder bridges located immediately below them on the back side of the board. These jumpers can be seen in [Figure 3](#). See [Table 3](#) for descriptions of these jumpers.

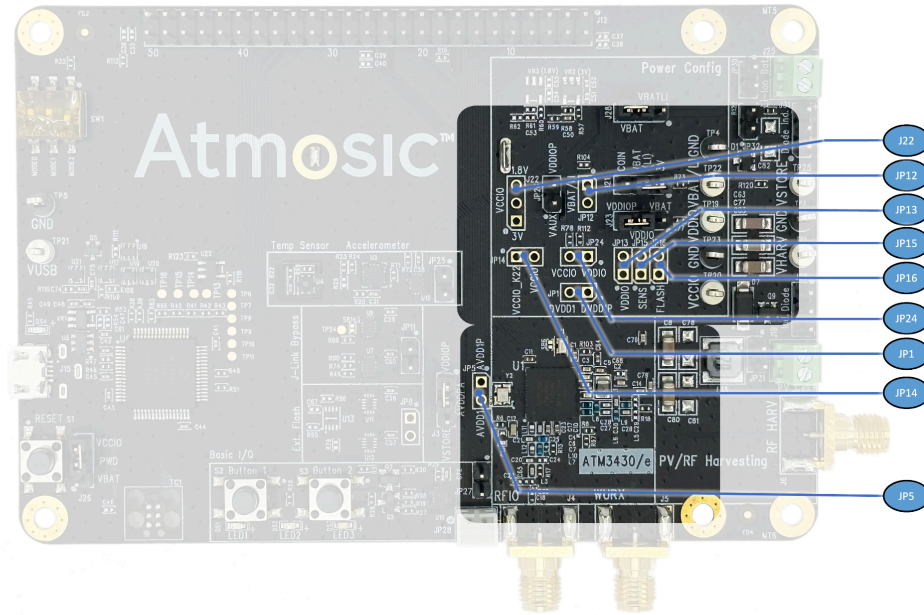

Figure 3 - ATM3430e QFN 7x7 mm Package v2.x EVB Jumper Locations

| Jumper | Solder Bridge | Description |
|--------|---------------|--|
| J22 | N/A | <ul style="list-style-type: none"> This 3-pin header allows VCCIO to be connected to fixed 1.8 V or 3.0 V supplied by onboard LDOs, instead of allowing VCCIO to automatically track VDDIO by default through the onboard VDDIO-VCCIO auto-tracking circuit. Note: If this is used, resistor R113 needs to be removed to disengage the auto-tracking circuit. |
| JP12 | SB136 | <ul style="list-style-type: none"> In series with the net VBAT and is shorted by the solder bridge SB136 on the back side. SB136 can be cut to allow for current measurements on VBAT. |
| JP13 | SB137 | <ul style="list-style-type: none"> In series with the net VDDIO and is shorted by the solder bridge SB137 on the back side. SB137 can be cut to allow for current measurements on VDDIO. |
| JP15 | SB140 | <ul style="list-style-type: none"> In series with the net VDDIO_SENS and is shorted by the solder bridge SB140 on the back side. SB140 can be cut to allow for measurements of currents drawn by the sensors. |

| Jumper | Solder Bridge | Description |
|--------|---------------|--|
| JP16 | SB141 | <ul style="list-style-type: none"> In series with the net VDDIO_FLASH (for external FLASH option) and is shorted by the solder bridge SB141 on the back side. SB141 can be cut to allow for measurements of currents drawn by the external flash. |
| JP24 | N/A | <ul style="list-style-type: none"> By default, not installed and not shorted by a solder bridge. If installed, it would connect the peripheral supply VCCIO with the ATM3430e VDDIO supply, useful for the case where the USB supply is not available. |
| JP1 | SB2 | <ul style="list-style-type: none"> In series with the net DVDD1 and is shorted by the solder bridge SB2 on the back side. SB2 can be cut to allow for current measurements on DVDD1. |
| JP14 | SB138 | <ul style="list-style-type: none"> In series with the net VCCIO_K22 and is shorted by the solder bridge SB138 on the back side. SB138 can be cut to allow for measurements of currents drawn by the MK22N processor. |
| JP5 | SB9 | <ul style="list-style-type: none"> In series with the net AVDD1 and is shorted by the solder bridge SB9 on the back side. SB9 can be cut to allow for current measurements on AVDD1. |

Table 3 - ATM3430e QFN 7x7 mm Package v2.x EVB Jumpers Descriptions

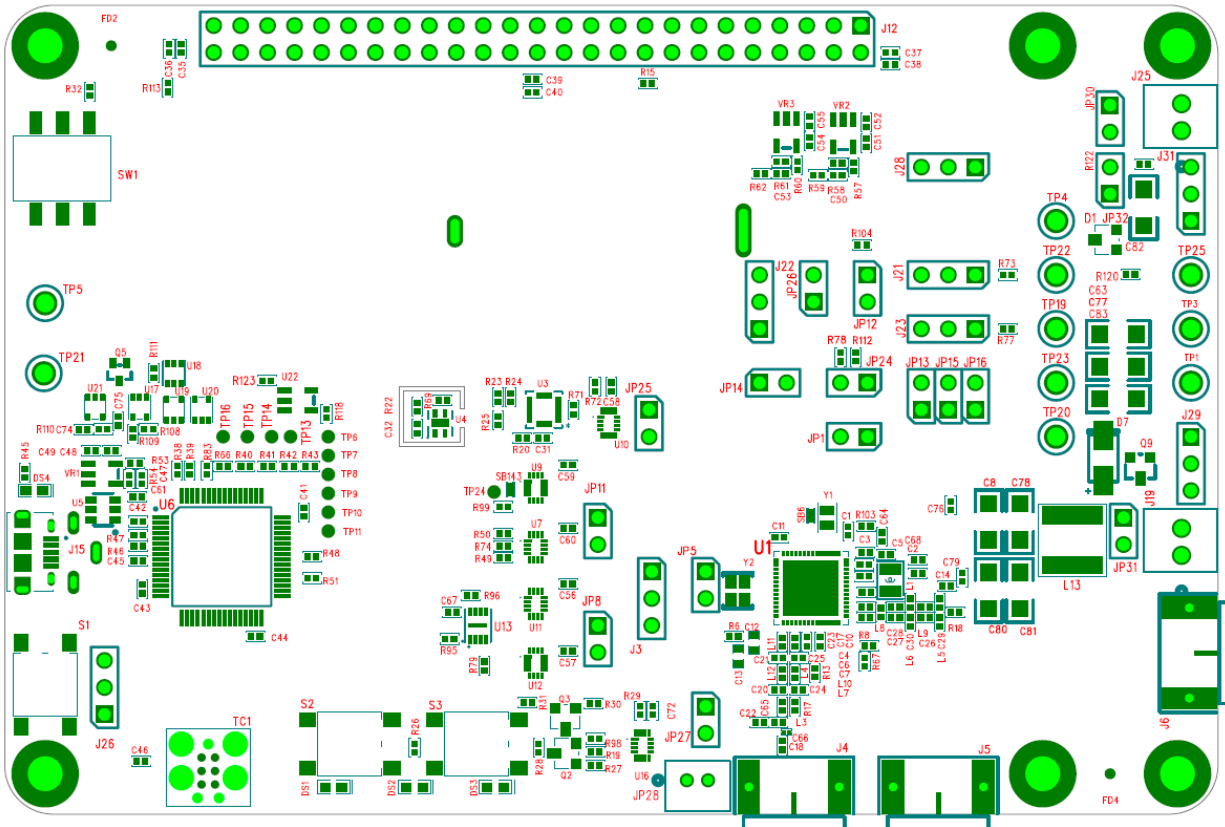

Figure 4 - ATM3430e QFN 7x7 mm Package v2.x EVB Top Silkscreen

The jumpers on the EVB have been configured for the following default mode of operation. See [Table 4](#).

| Default Configuration | Jumper |
|--|--------------------|
| The ATM3430e is powered through its VBAT pin 20 | J28:2-3 |
| The ATM3430e’s main supply, VBAT, comes from the coin cell battery | J21:2-3 |
| The ATM3430e I/O voltage (VDDIO) is supplied by an internally generated 1.8 V VDDIOP | J23:2-3 |
| Peripheral supply VCCIO automatically tracks I/O voltage (VDDIO) of ATM3430e | J22 not installed |
| External flash is NOT powered and NOT connected to the ATM3430e GPIOs | JP8 not installed |
| Sensors are NOT powered and NOT connected to the ATM3430e GPIOs | JP25 not installed |
| LEDs and Buttons are NOT powered and NOT connected to the ATM3430e GPIOs | JP27 not installed |
| SWD and UART signals are routed to the MK22N | JP11 not installed |

Table 4 - ATM3430e QFN 7x7 mm Package v2.x EVB Default Configurations

To reconfigure the EVB, the user can easily add, remove, or move jumpers. The user needs to match the software settings with the board configurations. Please refer to [Reconfigure the EVB](#) section for examples.

The EVB can also be further modified to allow for detailed current measurements if desired by cutting solder bridges and installing jumpers as previously mentioned.

To cut a solder bridge, simply use a blade to cut the thin trace that connects the two pads of the solder bridge. To short/close a solder bridge, simply use a soldering iron and some solder to fuse the two pads together. A microscope may be needed to make sure the connection has been thoroughly cut or fused.

3.2 ATM3405 BGA 4x4 mm EVB Description

Figure 5 highlights some of the key components of the ATM3405 BGA 4x4 mm EVB. Table 5 provides the descriptions of the labeled components.

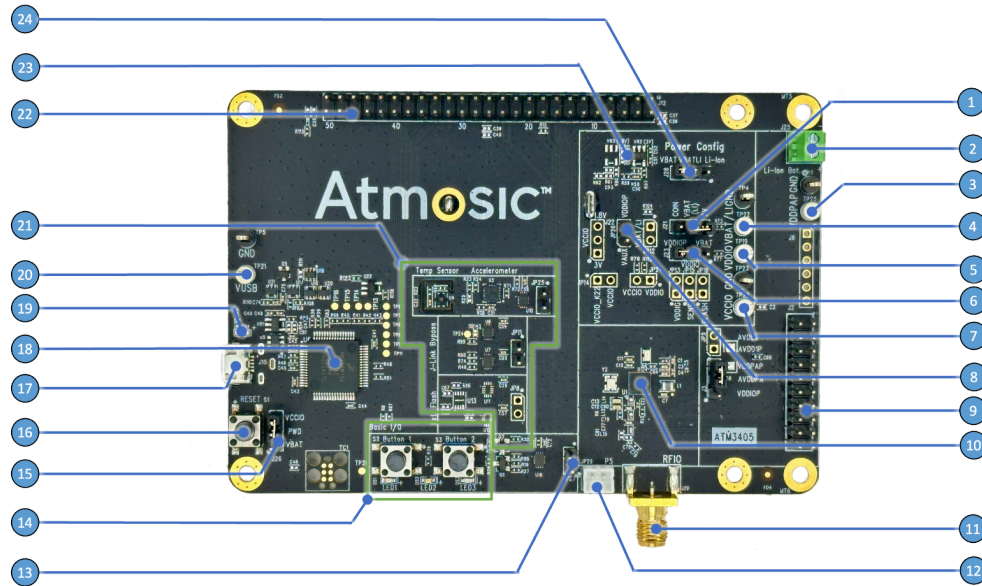

- | | | |
|--|---------------------------------------|--|
| 1 - VBAT Select Jumper (J21) | 16 - Reset Button (S1) | |
| 2 - Li-Ion Battery Connector (J25) | 17 - Micro-B USB Connector | |
| 3 - VDDPAP Test Point (TP25) | 18 - EVB Management Processor (MK22N) | |
| 4 - VBAT Test Point (TP22) | 19 - USB Power LED | |
| 5 - VDDIO Test Point (TP19) | 20 - USB Power Test Point (TP21) | |
| 6 - VDDIO Select Jumper (J23) | 21 - Peripherals & Enable Jumpers | |
| 7 - VCCIO Test Point (TP20) | 22 - 50-Pin Expansion Header (J12) | |
| 8 - VDDIOP Disable Jumper (JP26) | 23 - 1.8V/3.0V LDOs | |
| 9 - 20-pin Expansion Header (J2) | 24 - VBAT / VBATLI Select (J28) | |
| 10 - ATM3405 | | |
| 11 - Bluetooth LE RFIO Connector (J29) | | |
| 12 - Antenna Control Connector (JP29) | | |
| 13 - LED/Button Enable Jumper (JP27) | | |
| 14 - General Purpose I/O | | |
| 15 - Reset Voltage Select Jumper (J26) | | |
-
- | | |
|---------------------------|------|
| J-Link UART1 Disable: | JP8 |
| J-Link UART0/SWD Disable: | JP11 |
| Sensors: | JP25 |
-
- | | |
|----------------|--------|
| LED1: | RED |
| LED2: | YELLOW |
| LED3: | BLUE |
| Push Button 1: | (S2) |
| Push Button 2: | (S3) |

Figure 5 - ATM3405 BGA 4x4mm Package v0.x EVB Overview

| Item | Component | Description |
|------|--------------------------------|---|
| 1 | VBAT Select Jumper (J21) | <ul style="list-style-type: none"> J21 is used to connect VBAT of the ATM3405 to either the 3.0 V produced by the onboard LDO or the coin cell battery in the holder (BT2) mounted on the back of the board. For power profiling of ATM3405, VBAT can also be sourced externally by a power supply at any voltage (1.1 V - 3.3 V) through TP22, without any jumpers installed on J21. |
| 2 | Li-Ion Battery Connector (J25) | <ul style="list-style-type: none"> Connect a Li-Ion battery or a Hybrid Supercapacitor to the board. Note that the polarity of the connector is marked in white silkscreen. Insert the corresponding leads of the Li-Ion battery or Hybrid Supercapacitor into the connector and secure the leads by turning the screws clockwise until it's tight. |
| 3 | VDDPAP Test Point (TP25) | <ul style="list-style-type: none"> For internal use only. |
| 4 | VBAT Test Point (TP22) | <ul style="list-style-type: none"> Provide external VBAT voltage directly to the ATM3405 (not using the LDOs), or When an arbitrary VBAT voltage (different from 3 V) is desired. <p>Note: When TP22 is used, no jumper should be installed on J21.</p> |
| 5 | VDDIO Test Point (TP19) | <ul style="list-style-type: none"> TP19 is used to provide external VDDIO voltage directly to the ATM3405's I/O (not using the LDOs). This is used for power profiling or when a VDDIO voltage other than 1.8 V or VBAT is desired for the I/O supply of the ATM3405. <p>Note: When TP19 is used, no jumper should be installed on J23.</p> |
| 6 | VDDIO Select Jumper (J23) | <ul style="list-style-type: none"> J23 is used to connect VDDIO of the ATM3405 to either VDDIOP (internally generated 1.8 V by the ATM3405) or VBAT. Peripheral supply VCCIO will automatically track VDDIO by default through an onboard VDDIO-VCCIO auto-tracking circuit. For example, if VDDIO is connected to VDDIOP (using internally generated 1.8 V), then VCCIO will also automatically be 1.8 V. If VDDIO is connected to VBAT and VBAT is connected to 3.0 V, then VCCIO will also automatically be 3.0 V. |
| 7 | VCCIO Test Point (TP20) | <ul style="list-style-type: none"> Provide external VCCIO voltage for the peripheral devices on the board when the onboard 1.8 V or 3.0 V LDO or the auto-tracking circuit is not used (for example, when USB power is not available). <p>Note: When TP20 is used, no jumper should be installed on J22, and</p> |

| Item | Component | Description |
|------|-----------------------------------|--|
| | | <i>resistor R113 should be removed to disengage the auto-tracking circuit.</i> |
| 8 | VDDIOP Disable Jumper (JP26) | <ul style="list-style-type: none"> Install this Jumper JP26 when VDDIOP is not used to power VDDIO (J23) (see #4 above). <p>Note: <i>Install only if VDDIOP is not used to power the PA (J3) for output power greater than 4 dBm.</i></p> |
| 9 | 20-pin Expansion Header (J2) | <ul style="list-style-type: none"> For connection to test instruments. P35-P51 GPIOs are by default available on this header. |
| 10 | ATM3405 | <ul style="list-style-type: none"> 4x4 mm BGA 93-pin package |
| 11 | Bluetooth LE RFIO Connector (J29) | <ul style="list-style-type: none"> For connection to a 2.4 GHz antenna, or An instrument for conducted measurements. |
| 12 | Antenna Control Connector (JP29) | <ul style="list-style-type: none"> Optional for Channel Sounding feature with antenna diversity. Used to power an external RF SPDT antenna switch and switch between two antennas during Channel Sounding operation. |
| 13 | LED/Button Enable Jumper (JP27) | <ul style="list-style-type: none"> Install JP27 to enable the three LEDs (LED1, LED2, LED3) and Button 2. <ul style="list-style-type: none"> When JP27 is installed, the control signals for the LEDs and Button 2 are connected to the GPIOs of the ATM3405 through analog switches (U16) When JP27 is open, these control signals are disconnected, but there may be leakage currents of up to 5 nA per connection from the analog switches at room temperature <p>Note: <i>LED2 and LED3 are powered from the 3.3 V LDO, whereas LED1 is powered by the control signal itself.</i></p> <p>Note: <i>Button 1 and Button 2 are powered by the sensor supply and therefore require JP25 to be also installed for the sensor supply to be connected to VDDIO.</i></p> |
| 14 | General Purpose I/O | <ul style="list-style-type: none"> Install JP27 to enable the functionality of the LEDs: <ul style="list-style-type: none"> LED1: RED, driven directly by P29 LED2: YELLOW, driven by P9 through a NPN transistor. LED3: BLUE, driven by P10 through a NPN transistor. Install JP27 to enable. <ul style="list-style-type: none"> Button 1: S2 |

| Item | Component | Description |
|------|---|--|
| | | <ul style="list-style-type: none"> ○ Button 2: S3 |
| 15 | Reset Voltage Select Jumper (J26) | <ul style="list-style-type: none"> ● J26 is used to select whether the PWD signal used to reset the ATM3405 is sourced by VBAT or VCCIO. ● The option to use VCCIO is useful for accurate current measurements of the ATM3405 since the PWD signal current will be drawn from VCCIO, which is a separate domain from VBAT. ● Select VBAT when USB power is not available. |
| 16 | Reset Button (S1) | <ul style="list-style-type: none"> ● To assert PWD to the ATM3405 (pin K5) to reset the ATM3405. ● This pin is pulled low by default through the resistor R8 (10k Ω). ● When the button is pressed, it gets pulled high to VBAT or VCCIO (see description under Reset Voltage Select Jumper above) and thus resets the ATM3405. |
| 17 | Micro-B USB Connector | <ul style="list-style-type: none"> ● Provide power to the EVB as well as communication to the ATM3405. ● The 5 V from the USB powers the three Low-Drop-Out regulators to generate 3.3 V for the MK22N processor USB block and 3.0 V and 1.8 V options for the ATM3405. |
| 18 | EVB Management Processor (MK22N) | <ul style="list-style-type: none"> ● Used as a translation between USB and UART and SWD. <p><i>Note: the main supply voltage level of this processor is VCCIO and needs to match that of the I/O supply of the ATM3405. This is accomplished through the onboard VDDIO-VCCIO auto-tracking circuit.</i></p> |
| 19 | USB Power LED | <ul style="list-style-type: none"> ● The green LED lights up when the EVB is connected to a computer through the USB connector. |
| 20 | USB Power Test Point (TP21) | <ul style="list-style-type: none"> ● TP21 can be used to supply the board with an external 5 V in the case where a USB connection to the board is not available. ● This external 5 V will power the LDOs and enable the board to function without a host laptop, provided the ATM3405 has already been programmed and communication with a host laptop is not required. <p><i>Note: TP21 should not be used concurrently with a USB connection to a host laptop.</i></p> |
| 21 | Peripheral & Enable Jumpers (JP8, JP11, JP25) | <ul style="list-style-type: none"> ● Enable for Flash (JP8), J-Link bypass (JP11), and Sensors (JP25). ● Install JP8 to enable external Flash. <ul style="list-style-type: none"> ○ When JP8 is installed, the supply of the flash is connected to VDDIO, and I/Os of the flash are connected |

| Item | Component | Description |
|------|-------------------------------|---|
| | | <p>to the GPIOs of the ATM3405 through analog switches (U11, U12)</p> <ul style="list-style-type: none"> ○ When JP8 is open, the flash supply and I/Os are disconnected, but there may be leakage currents of up to 5 nA per connection from the analog switches at room temperature ● Install JP11 to disconnect the MK22N microcontroller I/O lines (SWD, UARTs) from the GPIOs of the ATM3405 by the analog switches (U7, U9). <ul style="list-style-type: none"> ○ This option is useful for accurate power profiling of the ATM3405 without interference from the MK22N ● Install JP25 to enable the temperature sensor and accelerometer. <ul style="list-style-type: none"> ○ When JP25 is installed, the supply of these two sensors is connected to VDDIO, and the I/Os of the sensors are connected to GPIOs of the ATM3405 through the analog switches (U10) ○ When JP25 is open, the sensor supply and I/Os are disconnected, but there may be leakage currents of up to 5 nA per connection from the analog switches at room temperature ● ENS210 Temperature and Humidity Sensor. <ul style="list-style-type: none"> ○ Used by the demo application, including HT_thermometer or Sensor Beacon ● LIS3DH Motion Sensor. <ul style="list-style-type: none"> ○ Used by the demo application, including HT_thermometer or Sensor Beacon |
| 22 | 50-Pin Expansion Header (J12) | <ul style="list-style-type: none"> ● For connection to test instruments. ● P0-P30 GPIOs are by default available on this header. |
| 23 | 1.8 V / 3.0 V LDOs | <ul style="list-style-type: none"> ● Supply voltages to the ATM3405 and other peripheral components using either 1.8 V or 3.0 V. ● These LDOs are powered by the USB power through the USB connector. |
| 24 | VBAT or VBATLI Select (J28) | <ul style="list-style-type: none"> ● Select VBAT (pins 2-3) to power the ATM3405 via the VBAT balls K6 and L5. |

| Item | Component | Description |
|------|-----------|--|
| | | <ul style="list-style-type: none"> Select VBATLI (pins 1-2) to power the ATM3405 via the VBATLI ball L11. |

Table 5 - ATM3405 BGA 4x4 mm Package v0.x EVB Main Components Descriptions

In addition to the configurable jumpers described above, there are a few other jumpers on the board that are not installed by default because they are normally not needed for typical use.

All these jumpers, except J22 and JP24, are shorted by default through solder bridges located immediately below them on the back side of the board.

These jumpers can be seen highlighted in green in [Figure 6](#). See [Table 6](#) for descriptions of these jumpers.

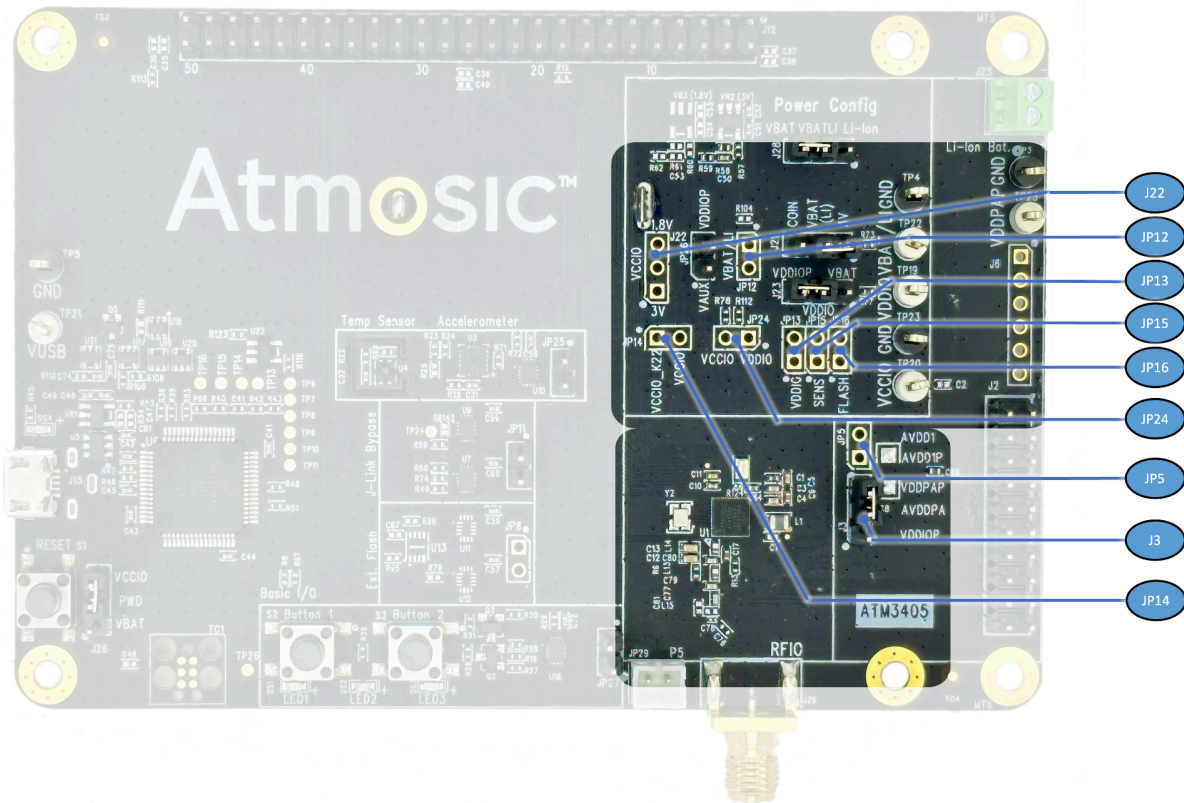

Figure 6 - ATM3405 BGA 4x4 mm Package v0.x EVB Jumper Locations

| Jumper | Solder Bridge | Description |
|--------|---------------|--|
| J22 | N/A | <ul style="list-style-type: none"> This 3-pin header allows VCCIO to be connected to fixed 1.8 V or 3.0 V supplied by onboard LDOs, instead of allowing VCCIO to automatically track VDDIO by default through the onboard VDDIO-VCCIO auto-tracking circuit. Note: If this is used, resistor R113 needs to be removed to disengage the auto-tracking circuit. |
| JP12 | SB136 | <ul style="list-style-type: none"> In series with the net VBAT and is shorted by the solder bridge SB136 on the back side. SB136 can be cut to allow for current measurements on VBAT. |
| JP13 | SB137 | <ul style="list-style-type: none"> In series with the net VDDIO and is shorted by the solder bridge SB137 on the back side. SB137 can be cut to allow for current measurements on VDDIO. |
| JP15 | SB140 | <ul style="list-style-type: none"> In series with the net VDDIO_SENS and is shorted by the solder bridge SB140 on the back side. SB140 can be cut to allow for measurements of currents drawn by the sensors. |
| JP16 | SB141 | <ul style="list-style-type: none"> In series with the net VDDIO_FLASH and is shorted by the solder bridge SB141 on the back side. SB141 can be cut to allow for measurements of currents drawn by the external flash. |
| JP24 | N/A | <ul style="list-style-type: none"> By default, not installed and not shorted by a solder bridge. If installed, it would connect the peripheral supply VCCIO with the ATM3405 VDDIO supply, useful for the case where the USB supply is not available. |
| JP5 | SB9 | <ul style="list-style-type: none"> In series with the net AVDD1 and is shorted by the solder bridge SB9 on the back side. SB9 can be cut to allow for current measurements on AVDD1. |
| J3 | | <ul style="list-style-type: none"> By default, a jumper should connect AVDDPA to VDDIOP (pin1-pin2). This allows the internal PA to be powered by internally generated 1.8 V VDDIOP for transmit power above 4 |

| Jumper | Solder Bridge | Description |
|--------|---------------|--|
| | | <p>dBm.</p> <ul style="list-style-type: none"> Connection from AVDDPA to VDDPAP (pin2-pin3) is for internal use only. |
| JP14 | SB138 | <ul style="list-style-type: none"> In series with the net VCCIO_K22 and is shorted by the solder bridge SB138 on the back side. SB138 can be cut to allow for measurements of currents drawn by the MK22N processor. |

Table 6 - ATM3405 BGA 4x4 mm Package v0.x EVB Jumpers Descriptions

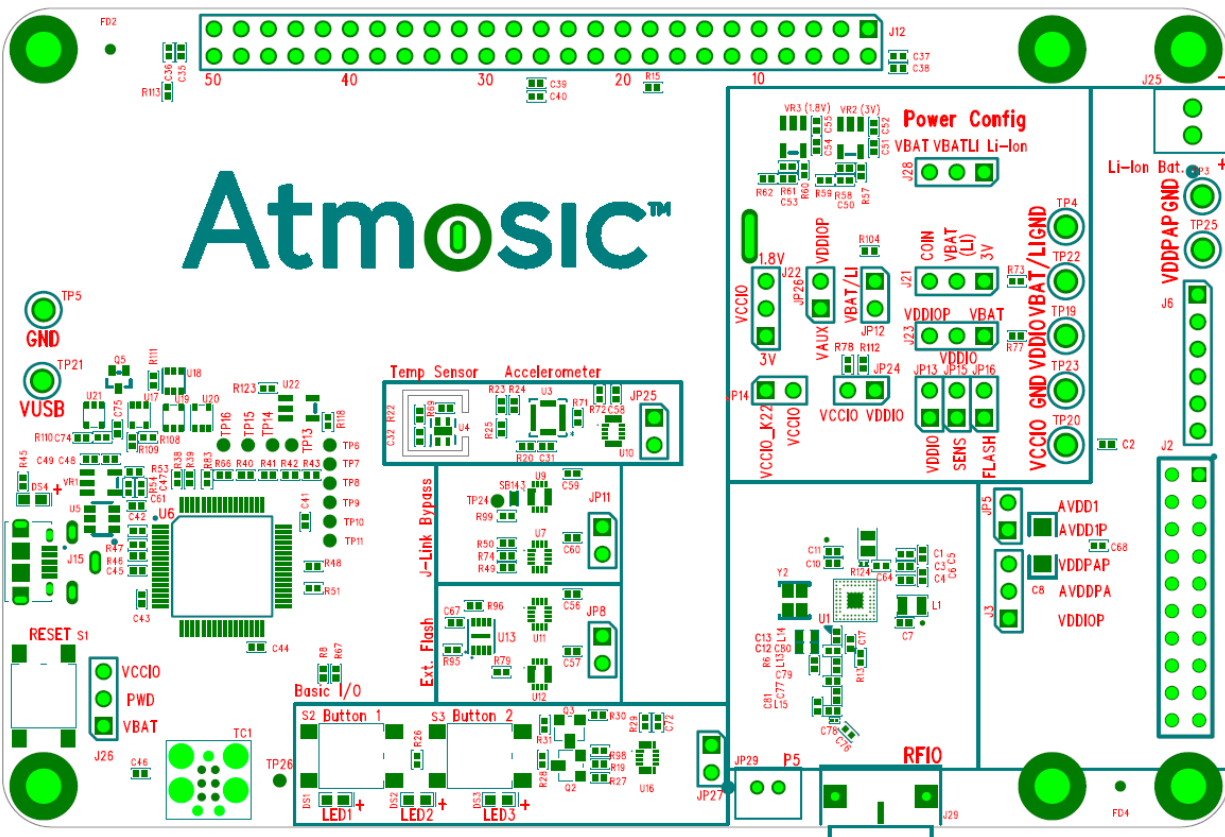

Figure 7 - ATM3405 BGA 4x4mm Package v0.x EVB Top Silkscreen

The jumpers on the EVB have been configured for the following default mode of operation. See [Table 7](#).

| Default Configuration | Jumper |
|---|--------------------|
| The ATM3405 is powered through its VBAT balls K6 and L5. | J28:2-3 |
| The ATM3405's main supply, VBAT, comes from the coin cell battery | J21:2-3 |
| The ATM3405 uses internal IO voltage supplied by 1.8 V VDDIOP | J23:2-3 |
| Peripheral supply VCCIO automatically tracks I/O voltage (VDDIO) of ATM3405 | J22 not installed |
| External flash is NOT powered and NOT connected to the ATM3405 GPIOs | JP8 not installed |
| Sensors are NOT powered and NOT connected to the ATM3405 GPIOs | JP25 not installed |
| LEDs and Buttons are NOT powered and NOT connected to the ATM3405 GPIOs | JP27 not installed |
| SWD and UART signals are routed to the MK22N | JP11 not installed |

Table 7 - ATM3405 BGA 4x4mm Package v0.x EVB Default Configurations

To reconfigure the EVB, the user can easily add, remove, or move jumpers. The EVB can also be further modified to allow for detailed current measurements if desired by cutting solder bridges and installing jumpers as previously mentioned.

To cut a solder bridge, simply use a blade to cut the thin trace that connects the two pads of the solder bridge. To short/close a solder bridge, simply use a soldering iron and some solder to fuse the two pads together. A microscope may be needed to make sure the connection has been thoroughly cut or fused.

The rest of this document describes the steps required to power and configure the EVB.

3.3 ATM3405 QFN 5x5 mm EVB Description

[Figure 8](#) highlights some of the key components of the ATM3405 QFN 5x5 mm EVB. [Table 8](#) provides the descriptions of the labeled components.

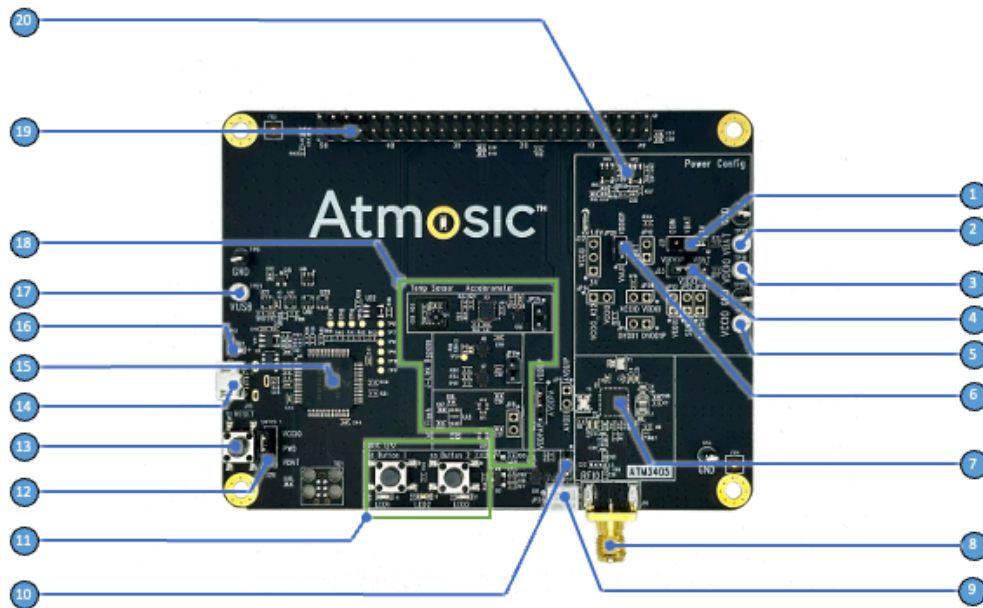

- | | |
|--|------------------------------------|
| 1 - VBAT Select Jumper (J21) | 16 - USB Power LED |
| 2 - VBAT Test Point (TP22) | 17 - USB Power Test Point (TP21) |
| 3 - VDDIO Test Point (TP19) | 18 - Peripherals & Enable Jumpers |
| 4 - VDDIO Select Jumper (J23) | 19 - 50-Pin Expansion Header (J12) |
| 5 - VCCIO Test Point (TP20) | 20 - 1.8V/3.0V LDOs |
| 6 - VDDIOP Disable Jumper (JP26) | |
| 7 - ATM3405 | |
| 8 - Bluetooth LE RFIO Connector (J4) | |
| 9 - Antenna Control Connector (JP28) | |
| 10 - LED/Button Enable Jumper (JP27) | |
| 11 - General Purpose I/O | |
| 12 - Reset Voltage Select Jumper (J26) | |
| 13 - Reset Button (S1) | |
| 14 - Micro-B USB Connector | |
| 15 - EVB Management Processor (MK22N) | |
- J-Link UART1 Disable: JP8
 J-Link UART0/SWD Disable: JP11
 Sensors: JP25
- LED1: RED
 LED2: YELLOW
 LED3: BLUE

Push Button 1: (S2)
 Push Button 2: (S3)

Figure 8 - ATM3405 QFN 5x5 mm Package v3.x EVB Overview

| Item | Component | Description |
|------|--------------------------|---|
| 1 | VBAT Select Jumper (J21) | <ul style="list-style-type: none"> J21 is used to connect VBAT of the ATM3405 to either the 3.0V produced by the on-board LDO or the coin cell battery in the holder (BT2) mounted on the back of the board. For power profiling of ATM3405, VBAT can also be sourced externally by a power supply at any voltage (1.1 V - 3.3 V) through |

| Item | Component | Description |
|------|----------------------------------|---|
| | | TP22, without any jumpers installed on J21. |
| 2 | VBAT Test Point (TP22) | <ul style="list-style-type: none"> Provide external VBAT voltage directly to the ATM3405 (not using the LDO's), or When an arbitrary VBAT voltage (different from 3 V) is desired. <p>Note: When TP22 is used, no jumper should be installed on J21.</p> |
| 3 | VDDIO Test Point (TP19) | <ul style="list-style-type: none"> TP19 is used to provide external VDDIO voltage directly to the ATM3405's I/O (not using the LDO's). This is used for power profiling or when a VDDIO voltage other than 1.8 V or VBAT is desired for the I/O supply of the ATM3405. <p>Note: when TP19 is used, no jumper should be installed on J23.</p> |
| 4 | VDDIO Select Jumper (J23) | <ul style="list-style-type: none"> J23 is used to connect VDDIO of the ATM3405 to either VDDIOP (internally generated 1.8 V by the ATM3405) or VBAT. Peripheral supply VCCIO will automatically track VDDIO by default through an on-board VDDIO-VCCIO auto-tracking circuit. For example, if VDDIO is connected to VDDIOP (using internally generated 1.8 V) then VCCIO will also automatically be 1.8V. If VDDIO is connected to VBAT and VBAT is connected to 3.0 V, then VCCIO will also automatically be 3.0V. |
| 5 | VCCIO Test Point (TP20) | <ul style="list-style-type: none"> Provide external VCCIO voltage for the peripheral devices on the board when the on-board 1.8V or 3.8V LDO or the auto-tracking circuit is not used (for example, when USB power is not available). <p>Note: When TP20 is used, no jumper should be installed on J22 and resistor R113 should be removed to disengage the auto-tracking circuit.</p> |
| 6 | VDDIOP Disable Jumper (JP26) | <ul style="list-style-type: none"> Install this Jumper JP26 when VDDIOP is not used to power VDDIO (J23) (see #4 above). <p>Note: Install only if VDDIOP is not used to power the PA (J3) for output power greater than 4dBm</p> |
| 7 | ATM3405 | 5x5 mm QFN 40-pin package with center GND pad. |
| 8 | Bluetooth LE RFIO Connector (J4) | <ul style="list-style-type: none"> For connection to a 2.4 GHz antenna, or An instrument for conducted measurements. |
| 9 | Antenna Control Connector (JP28) | <ul style="list-style-type: none"> Optional for Channel Sounding feature with antenna diversity. |

| Item | Component | Description |
|------|-----------------------------------|---|
| | | <ul style="list-style-type: none"> Used to power an external RF SPDT antenna switch and switch between two antennas during Channel Sounding operation. |
| 10 | LED/Button Enable Jumper (JP27) | <ul style="list-style-type: none"> Install JP27 to enable the three LEDs (LED1, LED2, LED3) and Button 2. <ul style="list-style-type: none"> When JP27 is installed, the control signals for the LEDs and Button 2 are connected to GPIOs of the ATM3405 through analog switches (U16). When JP27 is open these control signals are disconnected, but there may be leakage currents of up to 5 nA per connection from the analog switches at room temperature. <p><i>Note: LED2 and LED3 are powered from the 3.3 V LDO, whereas LED1 is powered by the control signal itself.</i></p> <p><i>Note: Button 1 and Button 2 are powered by sensor supply and therefore require JP25 to be also installed for the sensor supply to be connected to VDDIO.</i></p> |
| 11 | General Purpose I/O | <ul style="list-style-type: none"> Install JP27 to enable functionality of the LEDs: <ul style="list-style-type: none"> LED1 : RED, driven directly by P7 LED2 : YELLOW, driven by P6 through a NPN transistor. LED3 : BLUE, driven by P25 through a NPN transistor. Install also JP27 to enable <ul style="list-style-type: none"> Button 1 : S2 Button 2 : S3 |
| 12 | Reset Voltage Select Jumper (J26) | <ul style="list-style-type: none"> J26 is used to select whether the PWD signal used to reset the ATM3405 is sourced by VBAT or VCCIO. The option to use VCCIO is useful for accurate current measurements of the ATM3405 since the PWD signal current will be drawn from VCCIO, which is a separate domain from VBAT. Select VBAT when USB power is not available. |
| 13 | Reset Button (S1) | <ul style="list-style-type: none"> To assert PWD to the ATM3405 (pin 12) to reset the ATM3405. This pin is pulled low by default through the resistor R8 (1M Ω). When the button is pressed, it gets pulled high to VBAT or VCCIO (see description under Reset Voltage Select Jumper above) and thus resets the ATM3405. |
| 14 | Micro-B USB Connector | <ul style="list-style-type: none"> Provide power to the EVB as well as communication to the ATM3405. The 5 V from the USB powers the three Low-Drop-Out regulators to generate 3.3 V for the MK22N processor USB block and 3.0 V and 1.8 |

| Item | Component | Description |
|------|---|--|
| | | V options for the ATM3405. |
| 15 | EVB Management Processor (MK22N) | <ul style="list-style-type: none"> Used as a translation between USB and UART and SWD. <p>Note: the main supply voltage level of this processor is VCCIO and needs to match that of the I/O supply of the ATM3405. This is accomplished through the on-board VDDIO-VCCIO auto-tracking circuit.</p> |
| 16 | USB Power LED | <ul style="list-style-type: none"> Green LED lights up when the EVB is connected to a computer through the USB connector. |
| 17 | USB Power Test Point (TP21) | <ul style="list-style-type: none"> TP21 can be used to supply the board with an external 5 V in the case where a USB connection to the board is not available. This external 5 V will power the LDO's and enable the board to function without a host laptop, provided the ATM3405 has already been programmed and communication with a host laptop is not required. <p>Note: TP21 should not be used concurrently with a USB connection to a host laptop.</p> |
| 18 | Peripheral & Enable Jumpers (JP8, JP11, JP25) | <p>Enable for Flash (JP8), J-Link bypass (JP11), and Sensors (JP25)</p> <ul style="list-style-type: none"> Install JP8 to enable external Flash. <ul style="list-style-type: none"> When JP8 is installed, the supply of the flash is connected to VDDIO, and I/Os of the flash are connected to the GPIOs of the ATM3405 through analog switches (U11, U12). When JP8 is open, the flash supply and I/Os are disconnected, but there may be leakage currents of up to 5 nA per connection from the analog switches at room temperature. Install JP11 to disconnect the MK22N microcontroller I/O lines (SWD, UARTs) from the GPIOs of the ATM3405 by the analog switches (U7, U9). <ul style="list-style-type: none"> This option is useful for accurate power profiling of the ATM3405 without interference from the MK22N. Install JP25 to enable the temperature sensor and accelerometer. <ul style="list-style-type: none"> When JP25 is installed, the supply of these two sensors are connected to VDDIO, and the I/Os of the sensors are connected to GPIOs of the ATM3405 through the analog switches (U10). |

| Item | Component | Description |
|------|-------------------------------|--|
| | | <ul style="list-style-type: none"> ○ When JP25 is open, the sensor supply and I/Os are disconnected, but there may be leakage currents of up to 5 nA per connection from the analog switches at room temperature. ● ENS210 Temperature and Humidity Sensor <ul style="list-style-type: none"> ○ Used by the demo application including HT_thermometer or Sensor Beacon. ● LIS3DH Motion Sensor <ul style="list-style-type: none"> ○ Used by the demo application including HT_thermometer or Sensor Beacon. |
| 19 | 50-Pin Expansion Header (J12) | <ul style="list-style-type: none"> ● For connection to test instruments. ● All the GPIOs are by default available on this header. |
| 20 | 1.8 V / 3.0 V LDOs | <ul style="list-style-type: none"> ● Supply voltages to the ATM3405 and other peripheral components using either 1.8 V or 3.0 V. ● These LDO's are powered by the USB power through the USB connector. |

Table 8 - ATM3405 QFN 5x5 mm Package v3.x EVB Main Components Descriptions

In addition to the configurable jumpers described above, there are a few other jumpers on the board that are not installed by default because they are normally not needed for typical use.

All these jumpers except J22 and JP24 are shorted by default through solder bridges located immediately below them on the back side of the board.

These jumpers can be seen highlighted in green in [Figure 9](#). See [Table 9](#) for descriptions of these jumpers.

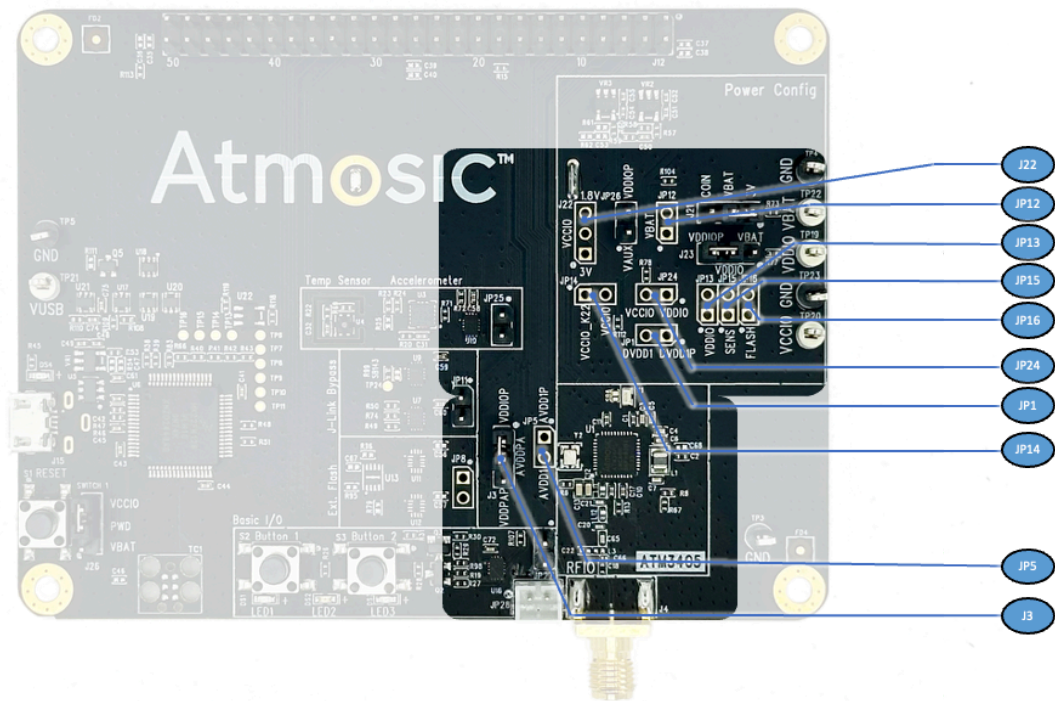

Figure 9 - ATM3405 QFN 5x5 mm Package v3.x EVB Jumper Locations

| Jumper | Solder Bridge | Description |
|--------|---------------|--|
| J22 | N/A | <ul style="list-style-type: none"> This 3-pin header allows VCCIO to be connected to fixed 1.8V or 3.0V supplied by on-board LDOs, instead of allowing VCCIO to automatically track VDDIO by default through the on-board VDDIO-VCCIO auto-tracking circuit. Note: If this is used, resistor R113 needs to be removed to disengage the auto-tracking circuit. |
| JP12 | SB136 | <ul style="list-style-type: none"> In series with the net VBAT and is shorted by the solder bridge SB136 on the back side. SB136 can be cut to allow for current measurements on VBAT. |
| JP13 | SB137 | <ul style="list-style-type: none"> In series with the net VDDIO and is shorted by the solder bridge SB137 on the back side. SB137 can be cut to allow for current measurements on VDDIO. |

| Jumper | Solder Bridge | Description |
|--------|---------------|--|
| JP15 | SB140 | <ul style="list-style-type: none"> In series with the net VDDIO_SENS and is shorted by the solder bridge SB140 on the back side. SB140 can be cut to allow for measurements of currents drawn by the sensors. |
| JP16 | SB141 | <ul style="list-style-type: none"> In series with the net VDDIO_FLASH and is shorted by the solder bridge SB141 on the back side. SB141 can be cut to allow for measurements of currents drawn by the external flash. |
| JP24 | N/A | <ul style="list-style-type: none"> By default not installed and not shorted by a solder bridge. If installed, it would connect the peripheral supply VCCIO with the ATM3405 VDDIO supply, useful for the case where USB supply is not available. |
| JP1 | SB2 | <ul style="list-style-type: none"> In series with the net DVDD1 and is shorted by the solder bridge SB2 on the back side. SB2 can be cut to allow for current measurements on DVDD1. |
| JP14 | SB138 | <ul style="list-style-type: none"> In series with the net VCCIO_K22 and is shorted by the solder bridge SB138 on the back side. SB138 can be cut to allow for measurements of currents drawn by the MK22N processor. |
| JP5 | SB9 | <ul style="list-style-type: none"> In series with the net AVDD1 and is shorted by the solder bridge SB9 on the back side. SB9 can be cut to allow for current measurements on AVDD1. |
| J3 | N/A | <ul style="list-style-type: none"> By default J3 is configured such that VDDIOP is used as the supply for VDDPA. A jumper is installed between pin 1 and pin 2 by default. VDDPAP connection to VDDPA is for internal use only. |

Table 9 - ATM3405 QFN 5x5 mm Package v3.x EVB Jumpers Descriptions

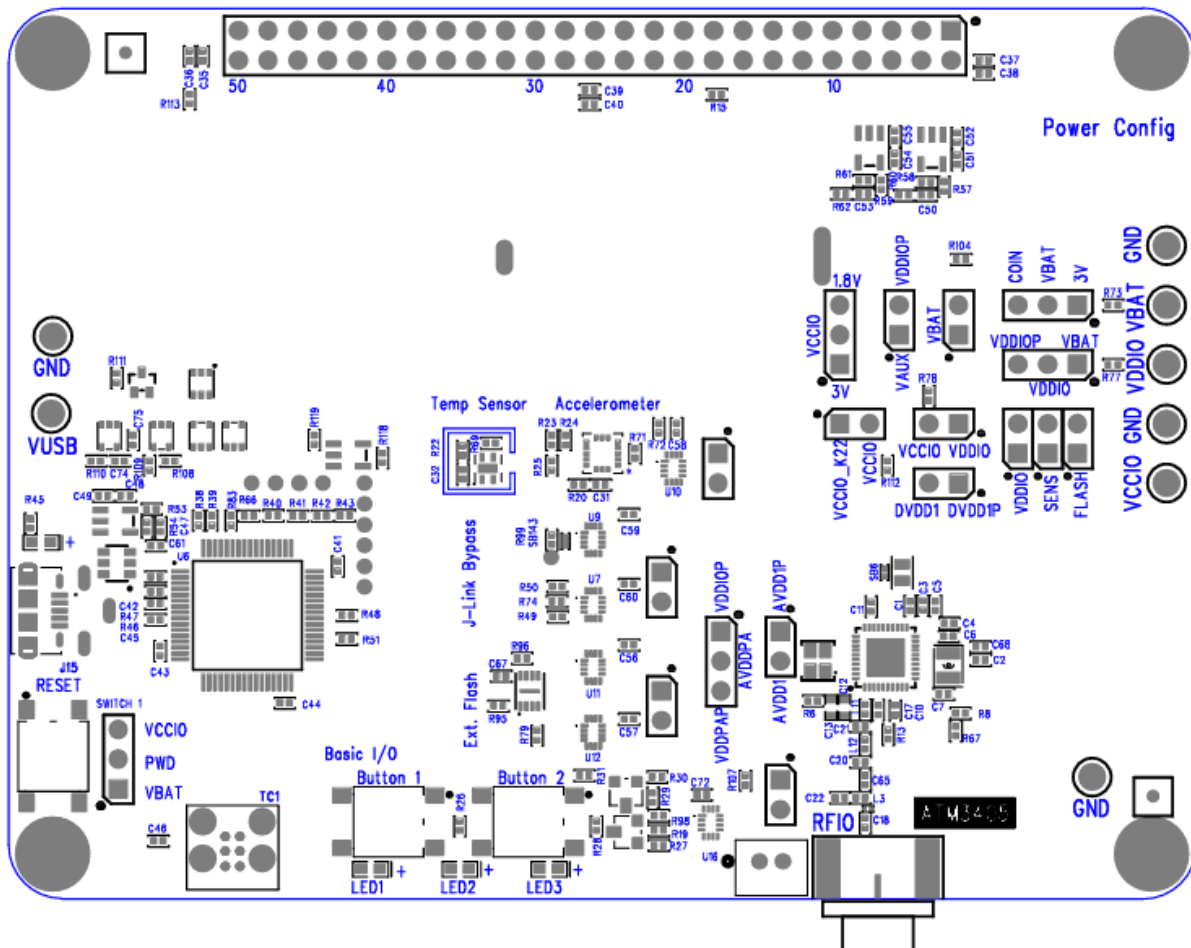

Figure 10 - ATM3405 QFN 5x5 mm Package v3.x EVB Top Silkscreen

The jumpers on the EVB have been configured for the following default mode of operation. See [Table 10](#).

| Default Configuration | Jumper |
|---|--------------------|
| The ATM3405’s main supply VBAT comes from the coin cell battery | J21:2-3 |
| The ATM3405 uses internal IO voltage supplied by 1.8 V VDDIOP | J23:2-3 |
| Peripheral supply VCCIO automatically tracks I/O voltage (VDDIO) of ATM3405 | J22 not installed |
| External flash is NOT powered and NOT connected to the ATM3405 GPIOs | JP8 not installed |
| Sensors are NOT powered and NOT connected to the ATM34055 GPIOs | JP25 not installed |
| LEDs and Buttons are NOT powered and NOT connected to the ATM3405 GPIOs | JP27 not installed |

| Default Configuration | Jumper |
|--|--------------------|
| SWD and UART signals are routed to the MK22N | JP11 not installed |

Table 10 - ATM3405 QFN 5x5 mm Package v3.x EVB Default Configurations

To reconfigure the EVB, the user can easily add, remove, or move jumpers. The EVB can also be further modified to allow for detailed current measurements if desired by cutting solder bridges and installing jumpers as previously mentioned.

To cut a solder bridge, simply use a blade to cut the thin trace that connects the two pads of the solder bridge. To short/close a solder bridge, simply use a soldering iron and some solder to fuse the two pads together. A microscope may be needed to make sure the connection has been thoroughly cut or fused.

The rest of this document describes the steps required to power and configure the EVB.

4. VDDIO Voltage

The EVB is configured out of the box to support VDDIO of 1.8 V. It can be reconfigured to be the same as VBAT by moving the jumper on J23. In this case, JP26 should be installed if the Power Amplifier is not set to output more than 4 dBm.

For VDDIO voltages other than these two options, an external power supply should be used. The user needs to match the software settings with the board configurations. Please refer to [Reconfigure the EVB](#) section for examples.

5. Powering on the EVB via the USB Connector

The EVB is configured out of the box to send out Bluetooth LE advertisement beacons once the coin cell battery included in the kit is inserted into the holder at the back side of the EVB, without the need for a PC.

Alternatively, the EVB can also be powered through the USB connector. To do that, connect the EVB to a PC using the supplied USB cable. The green USB Power LED next to the USB connector of the EVB should light up, indicating that it is receiving 5 V from the PC's USB port. J21 can then be set to 3 V to power the ATM34/e by the onboard 3 V LDO.

The beacons can be detected over the air by any Bluetooth sniffer phone app if the 2.4 GHz antenna (the shorter of the two antennas included in the kit) is connected to the SMA connector labeled RFIO and the phone is placed close to the EVB.

6. Reconfigure the EVB

Here are a few examples to reconfigure the EVB. Please refer to the **ATM34_e Series Reference Manual** 'PMU Configurations' section for the actual software settings.

Example 1: The default EVB assumes a non-rechargeable battery on VBAT. To reconfigure the device to use VBATLI, please refer to the **ATM34/e Energy Harvesting EVK Quick Start Guide** and **ATM34_e Support for External Storage Devices Application Note**.

Example 2: The default EVB assumes $V_{BAT} > 1.8\text{ V}$. To reprogram the device for V_{BAT} range $\leq 1.8\text{ V}$, the following procedure needs to be followed:

- 1) Power the device with $V_{BAT} > 1.8\text{ V}$.
- 2) Reprogram the device to indicate $V_{BAT} \leq 1.8\text{ V}$.
- 3) Supply the device with V_{BAT} at the target level.
- 4) Proceed with evaluation.

Example 3: The default EVB assumes an internally generated I/O supply. To reprogram the device for external I/O supply, the following procedure needs to be followed:

- 1) Power down the device.
- 2) Change the hardware jumpers according to the [VDDIO Voltage](#) section.
- 3) Power up the device.
- 4) Reprogram the device to indicate an externally generated I/O supply.
- 5) Proceed with evaluation.

7. Making Measurements with the EVB

The EVB can be used to evaluate many performance metrics of the ATM34/e. To obtain accurate results, certain measurements require correct board configurations and/or careful setups and procedures. The following lists some examples:

- Conducted Receiver Sensitivity measurements:
 - Good low-loss and well matched ($Z_0=50\text{ohms}$ up to at least 3GHz) RF cables should be used between the tester and the EVB if needed and this loss should be subtracted from the results. For an optimum setup, direct SMA-to-SMA connection is recommended.

- The entire setup should be shielded to avoid ambient RF interference. Degradation in sensitivity on certain channels at different measurement times may be an indication of interference.
- It is crucial that the EVB RFIO Connector (J4) be well terminated with 50 ohms before the EVB is powered on for the measurements because the receiver calibration routine, which occurs at power-up, can be impacted by the input impedance of the receiver. This proper sequence can be done by simply connecting the EVB to the tester first, before powering on the EVB, or by pressing the Reset Button (S1) on the EVB after the RFIO Connector has been connected to the tester input SMA.

Reference Documents

| Title | Document Number |
|--------------------------|-----------------|
| ATM34/e Series Datasheet | 6494-xxxx-xxxx |

Revision History

| Date | Version | Description |
|-------------------|---------|--|
| June 25, 2026 | 0.16 | Updated ATM3430e QFN 7x7 mm Package v2.x EVB Overview (corrected numbering); Updated ATM3405 BGA 4x4mm Package v0.x EVB Overview (added item 24) |
| December 30, 2025 | 0.15 | Added Making Measurements with the EVB |
| August 22, 2025 | 0.14 | Updated ATM3405 QFN 5x5 mm Package v3.x EVB Jumpers Descriptions |
| August 18, 2025 | 0.13 | Added EVB - ATM3405 QFN 5x5mm EVB |
| June 9, 2025 | 0.12 | Update with latest EVB offering - ATM3430e QFN 7x7mm EVB; ATM3405 BGA 4x4mm EVB |
| January 24, 2024 | 0.11 | Update to Table 1 - Applicable SoCs and EVKs |
| November 7, 2023 | 0.10 | Initial version created. |



ATMOSIC TECHNOLOGIES – DISCLAIMER

This product document is intended to be a general informational aid and not a substitute for any literature or labeling accompanying your purchase of the Atmosic product. Atmosic reserves the right to amend its product literature at any time without notice and for any reason, including to improve product design or function. While Atmosic strives to make its documents accurate and current, Atmosic makes no warranty or representation that the information contained in this document is completely accurate, and Atmosic hereby disclaims (i) any and all liability for any errors or inaccuracies contained in any document or in any other product literature and any damages or lost profits resulting therefrom; (ii) any and all liability and responsibility for any action you take or fail to take based on the information contained in this document; and (iii) any and all implied warranties which may attach to this document, including warranties of fitness for particular purpose, non-infringement and merchantability. Consequently, you assume all risk in your use of this document, the Atmosic product, and in any action you take or fail to take based upon the information in this document. Any statements in this document in regard to the suitability of an Atmosic product for certain types of applications are based on Atmosic's general knowledge of typical requirements in generic applications and are not binding statements about the suitability of Atmosic products for any particular application. It is your responsibility as the customer to validate that a particular Atmosic product is suitable for use in a particular application. All content in this document is proprietary, copyrighted, and owned or licensed by Atmosic, and any unauthorized use of content or trademarks contained herein is strictly prohibited.

Copyright ©2021-2026 by Atmosic Technologies. All rights reserved. Atmosic logo is a registered trademark of Atmosic Technologies Inc. All other trademarks are the properties of their respective holders.

Atmosic™

Atmosic Technologies | 2130 Gold Street #200 | San Jose, CA 95002

www.atmosic.com