

# REFERENCE DESIGN INTERFACE BOARD VERSION 3

Release Date	Revision	Design Eng.	Design Note
02/23/2019	Rev. A	DN	Initial release
06/20/2019	Rev. B	DN	<ul style="list-style-type: none"> <li>- Fixed 2.5V pull around JP10.</li> <li>- Added bypass caps for level shifters.</li> <li>- Deleted J8 and connected JTAG signals to TP.</li> </ul>
05/14/2020	Rev. C	CL	Added USB ESD protection Added LED for USB power indication Added 10-pin header J5 for J-Link support Added 10-pin header J4 for TC2050 Plug-of-Nail support Fixed VCC_BD_3V to 3.0V Fixed VCC_BUCK to only 2.5V Changed PWD / BBOOT level shifter to unidirectional part Replaced several headers with 0 ohm resistors

**Atmosic Technologies, Inc**  
 910 E. Hamilton Ave, Suite 550  
 Campbell, CA 95008, USA

ATMOSIC TECHNOLOGIES INC		
Title		
REFERENCE DESIGN INTERFACE BOARD VERSION 3		
Size	Document Number	Rev
B	<Doc>	C
Date:	Tuesday, June 16, 2020	Sheet 1 of 6

**Atmosic Technologies Proprietary and Confidential**

# GPIOS SELECTION

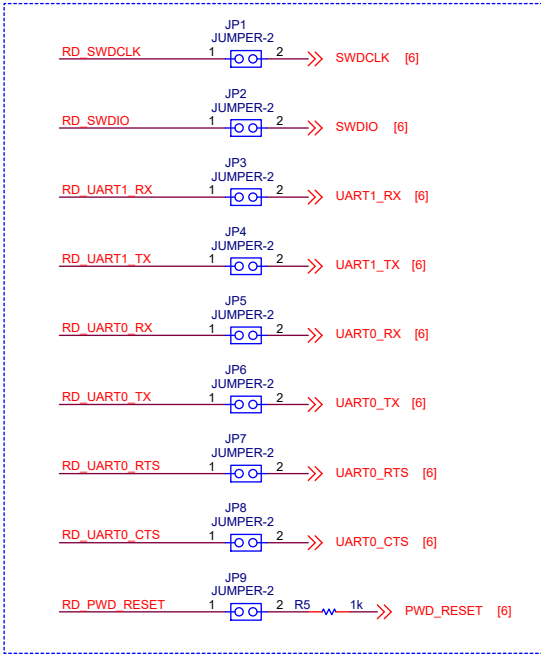

# FROM REFERENCE DESIGN

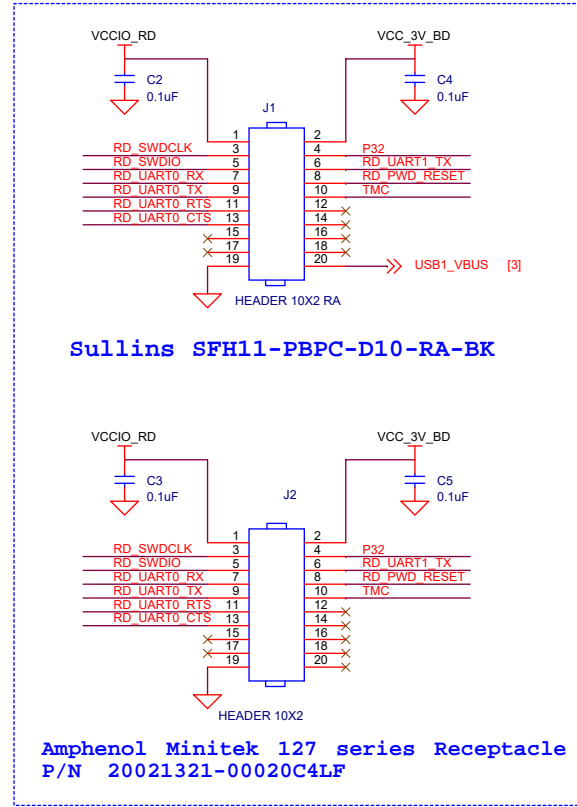

# J-Link

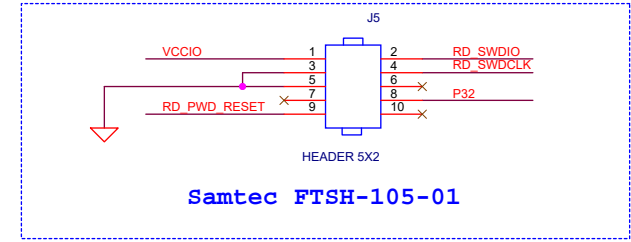

# TC2050 10 Pin

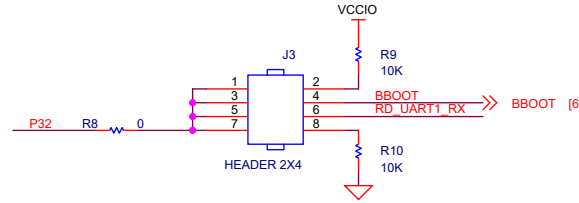
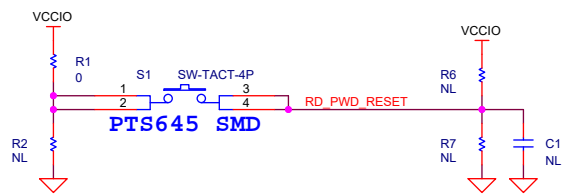
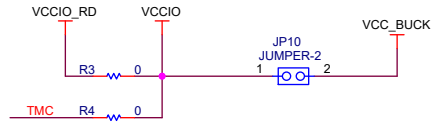
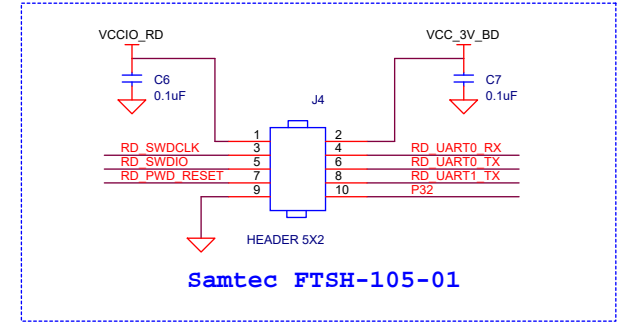

	6x6	5x5
FTDI2_UART0_TX	P10	P25
FTDI2_UART0_RX	P11	P13
FTDI2_UART0_CTS	P12	P10
FTDI2_UART0_RTS	P13	P11

ATMOSIC TECHNOLOGIES INC		
Title		
REFERENCE DESIGN INTERFACE BOARD VERSION 3		
Size B	Document Number <Doc>	Rev C
Date: Tuesday, June 16, 2020	Sheet 2 of 6	

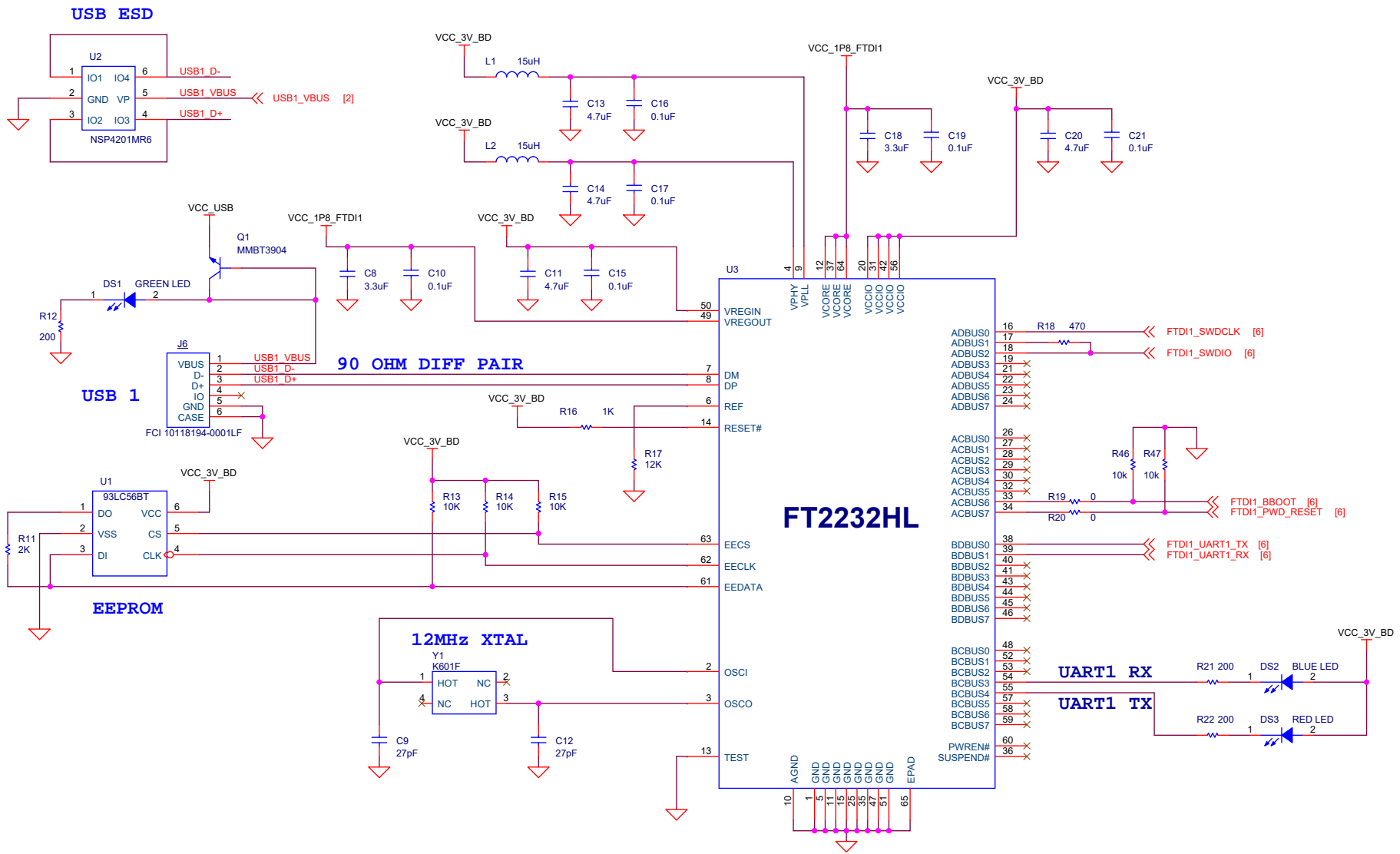

<b>ATMOSIC TECHNOLOGIES INC</b>		
Title		
REFERENCE DESIGN INTERFACE BOARD VERSION 3		
Size	Document Number	Rev
B	<Doc>	C
Date:	Tuesday, June 16, 2020	Sheet 3 of 6

Atmosic Technologies Proprietary and Confidential

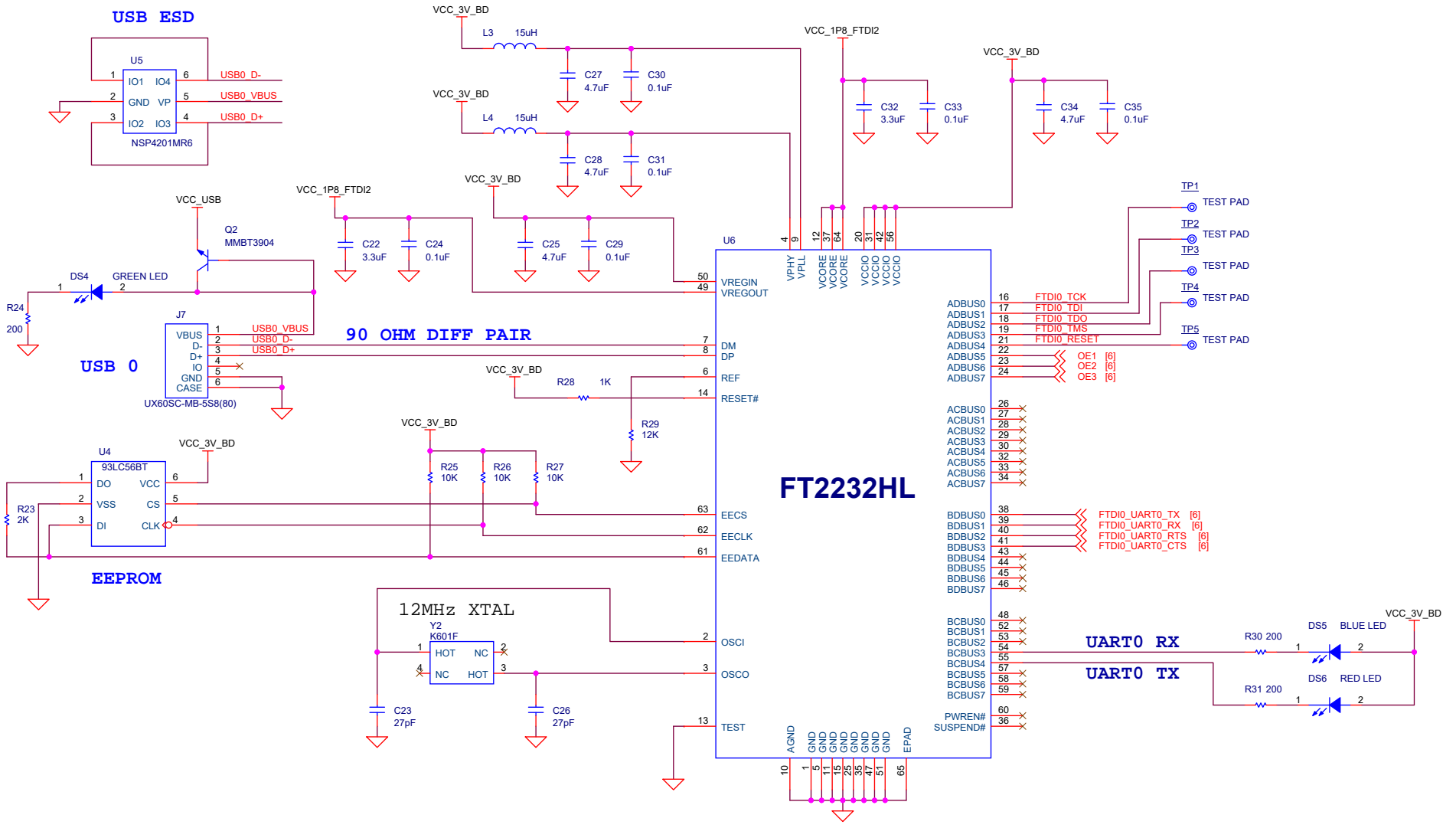

Atmosic Technologies Proprietary and Confidential

ATMOSIC TECHNOLOGIES INC		
Title		
REFERENCE DESIGN INTERFACE BOARD VERSION 3		
Size	Document Number	Rev
B	<Doc>	C
Date:	Tuesday, June 16, 2020	Sheet 4 of 6

# Voltage Regulators

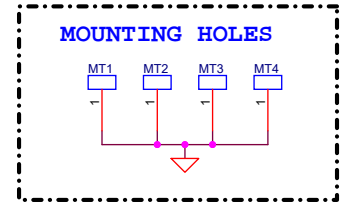
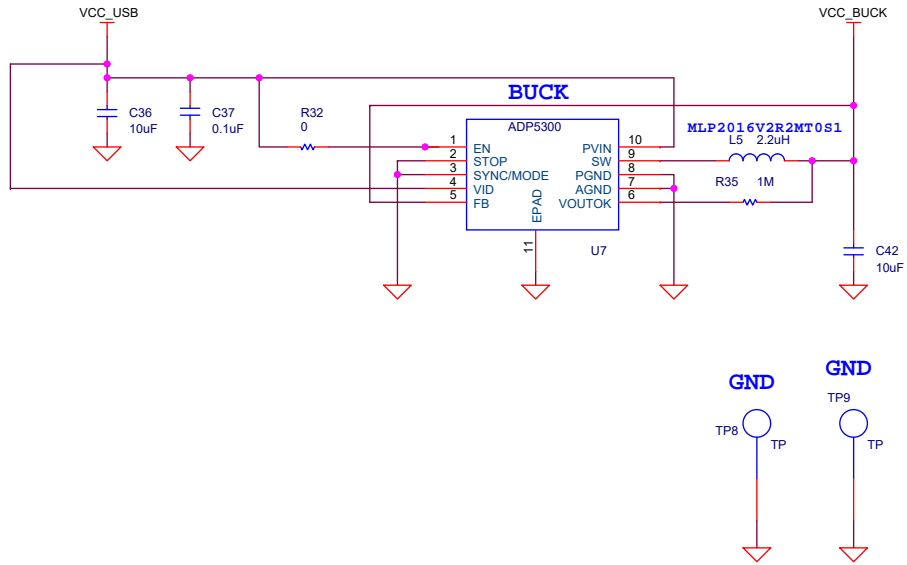
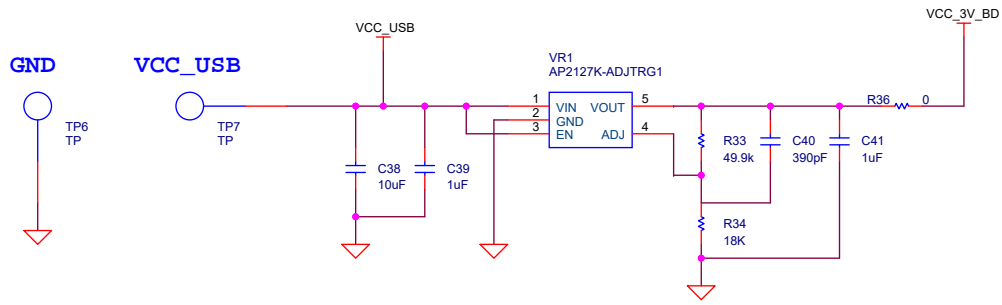

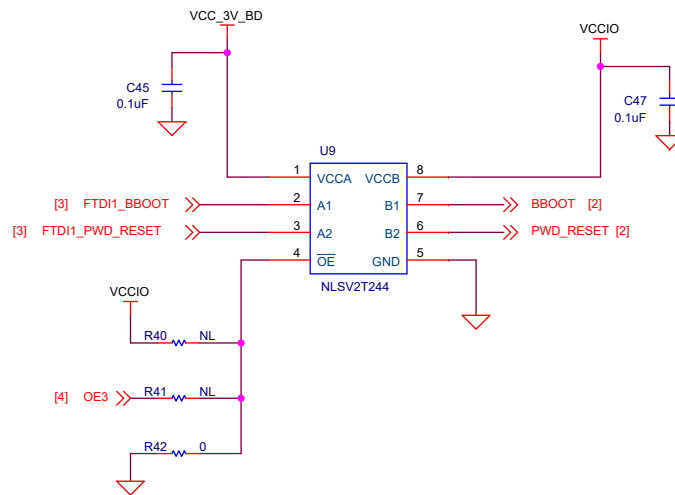
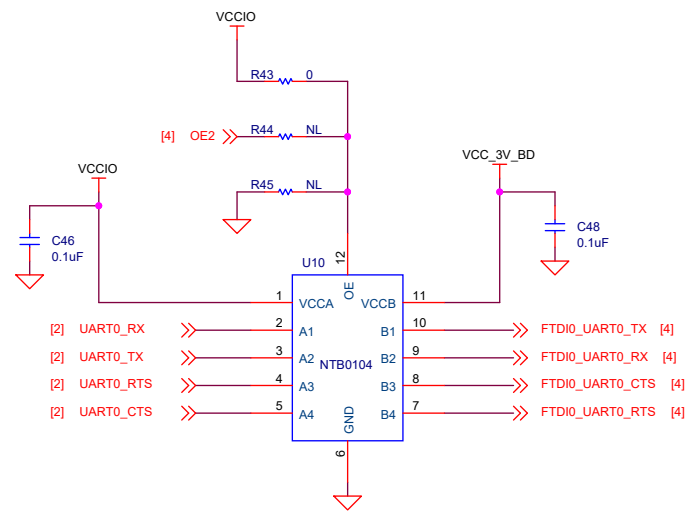
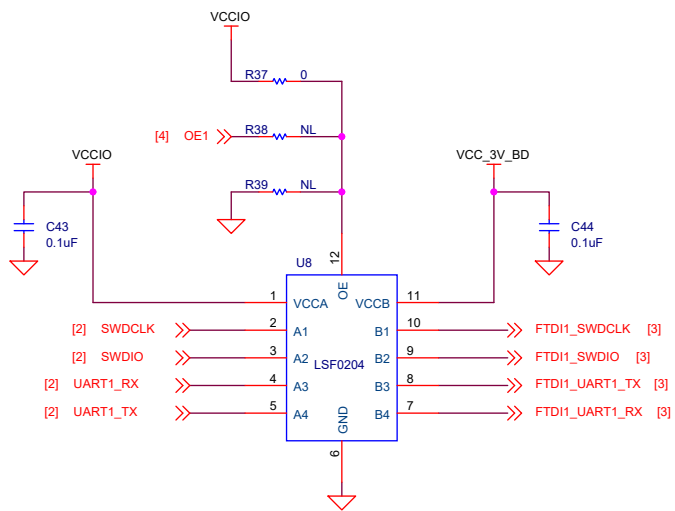

<b>ATMOSIC TECHNOLOGIES INC</b>		
Title		
REFERENCE DESIGN INTERFACE BOARD VERSION 3		
Size	Document Number	Rev
B	<Doc>	C
Date:	Tuesday, June 16, 2020	Sheet 6 of 6